

**Horizon**

# AFC-544AKTSC/546AKTSC

Press Stacker PST-40

Press Stacking & Semi-auto Bundling Unit TST-37



think  
automation.

※1 Equipped with 6 buckle plates for a wide variety of folding.  
 The AFC-544AKTSC/546AKTSC features user-friendly operation with automatic adjustment function.

※1 AFC-544AKTSC is equipped with 4 buckles.

- ※2 17 fold patterns -- including 8-page cross fold, letter fold, and DL fold - are set by simply touching the icon for desired fold pattern and inputting the paper size on the large LCD touch-screen. ※3 12 different sections are set automatically by stepper motor.
- High production speed (belt speed 230 m (250 yd.)/min., 35,000 sheets/hr. (A4 / 8.5" x 11" -parallel fold), 43,000 sheets/hr. (A5 / 5.5" x 8.5" -parallel fold)).
- Optional extension table and suction head stay can be provided for gate folding operation.
- Advanced urethane foam (soft PU) rubber ensures accurate folding.
- The automated set-up takes just 14 seconds. The LCD touch-screen prompts the operator through all remaining settings, for fast, efficient production. All adjustments are user-friendly and require minimal skill or training.
- The AFC-544AKTSC/546AKTSC lets you memorize up to 100 different job settings, for quick and easy restart of regular jobs. In addition to sheet size, you can memorize belt speed, suction time, feed intervals, knife delay time, press stacker setting (option), and the date to store the job.
- The Operation Record Indicator provides complete system status at a glance.
- A wide range of optional accessories -- such as gate fold buckle, press stacker, edge-trim device, strip trim device, and gluing unit -- help you tackle a wide range of folding applications.
- Optional devices such as gate fold buckle and press stacker can be set-up and operated through the main LCD console on the AFC-544AKTSC/546AKTSC.
- The AFC-544AKTSC/546AKTSC can be enhanced with Horizon's unique ※4 i2i network flow system.

※2 14 fold patterns are set on the AFC-544AKTSC.  
 ※3 10 sections are set on the AFC-544AKTSC.  
 ※4 The i2i system is option.

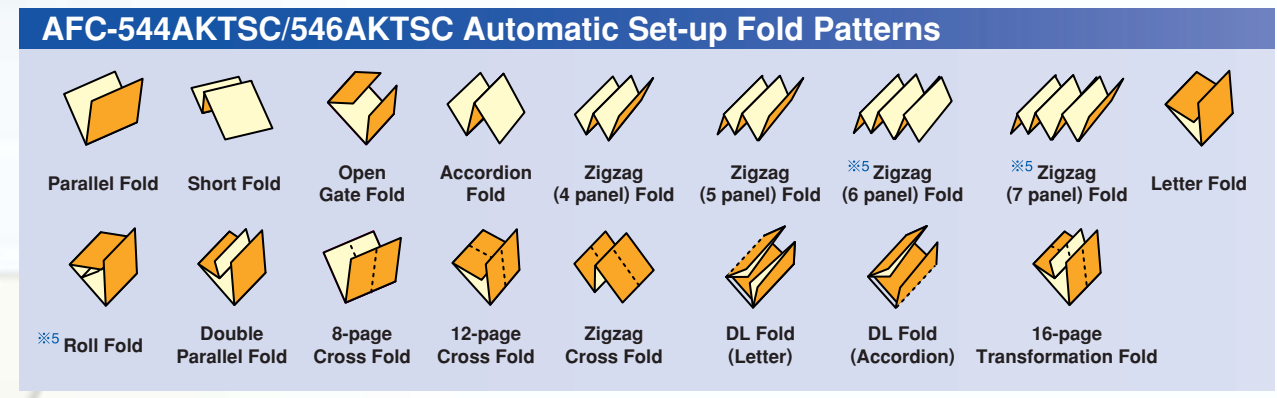

※5 For AFC-546AKTSC Only



AFC-546AKTSC + PST-40 (Option)

What is i2i System?



The Horizon i2i system can be integrated with pre-press and printing workflow to create a comprehensive automated CIP4 bindery with the prospect of jobs passing from the eye of the creator to the eye of the beholder in a single i2i Net>Work>Flow for ultimate flexibility and efficiency in the on-demand era.

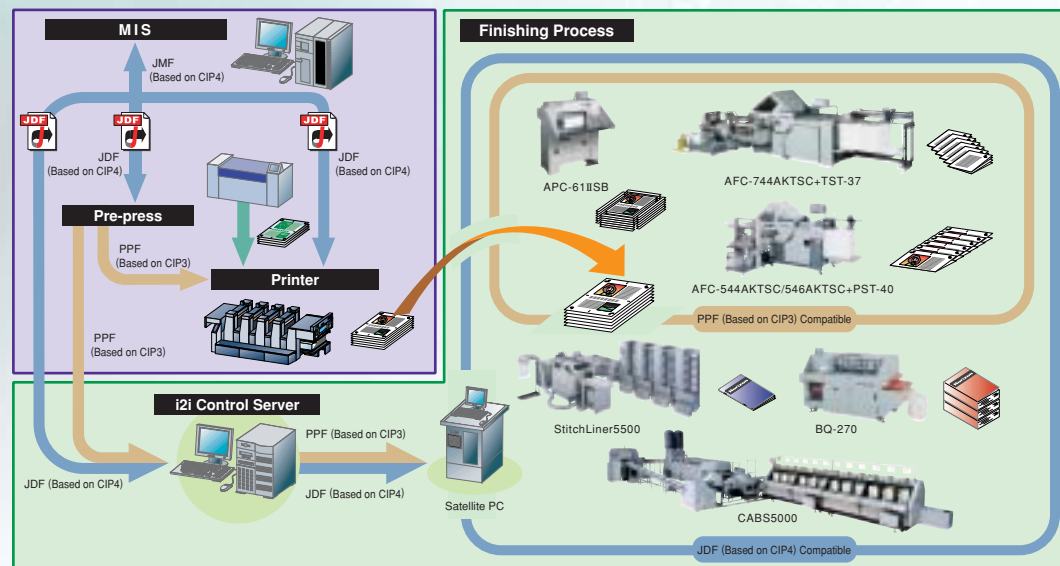

Sheet Flow with Cross Folding Operation

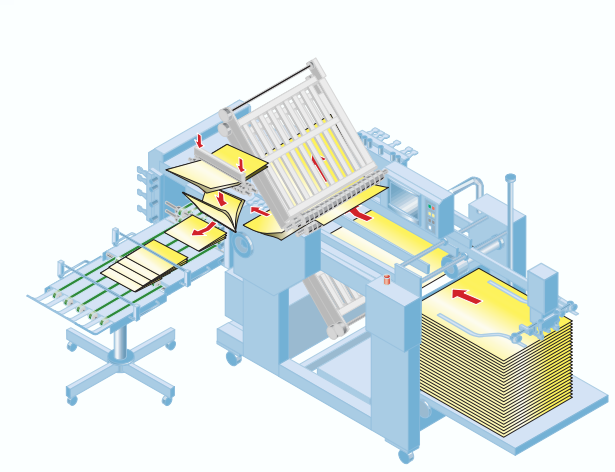

Sheet Flow with Parallel Folding Operation

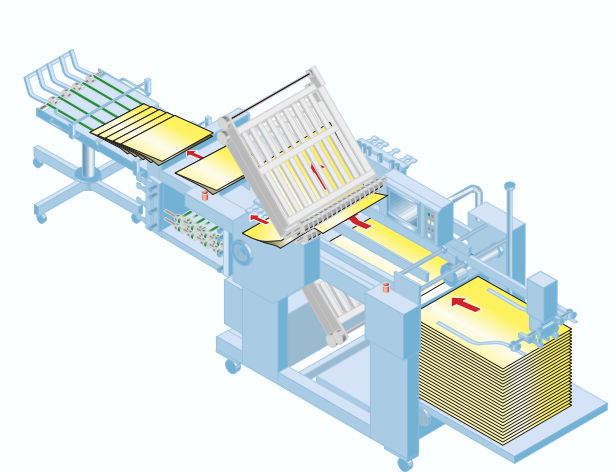

**The AFC-544AKTSC/546AKTSC computer controlled cross-folder is precision engineered for quality folding in minimum space.**

**The large icon-based touch-screen provides a simple, powerful user interface.**

**The AFC-544AKTSC/546AKTSC combines Horizon's advanced folding technology with simple operation and superior folding quality.**

**AUTO** 1st to 6th Buckles ※2



- The specially-coated fold plate creates less friction with the paper to help maintain fold accuracy.
- The buckle section is set-up automatically by inputting the fold pattern and sheet size via the LCD touch-screen display.
- The buckle has a simple flip-over deflector.



**Conveyor**

- Conveyor height can be adjusted by the hand wheel to the proper sheet delivery height.

**Sub-Operation Panel**

- Basic operation- Start, Stop, Inching operation, and Test feeding are possible to perform.

**AUTO** Knife Stopper   **AUTO** Two Knife Guides   **AUTO** Two Buckles Below Knife

**Fold Knife**



- The servomotor-controlled knife can fold 24,000 sheets/hr.
- The feed interval is automatically set according to the knife delay time for maximum folding efficiency.
- The ability to inch the knife avoids trial-and-error test folding.

**AUTO** SHOWS AUTOMATED SET-UP SECTIONS.

A total of ※12 sections (※21st to 6th buckles; knife stopper, two knife guides, and two buckles below knife at the fold knife section; and side lay guide) are set-up automatically.

※1 A total of 10 sections are set automatically on the AFC-544AKTSC.  
 ※2 The 1st to 4th buckles are set automatically on the AFC-544AKTSC.



**Perforation**



- The system supports perforation, slit perforation, scoring, slitting, and strip trimming.
- The perforation shaft is quick and easy to install or detach.
- 3 sets of cutter blade holders are provided standard. Three perforation and two scoring operations are possible. A maximum of 12 blades can be attached.

**Folding Rollers**



Helical gears driven with flexible cross couplings for quality fold.

- The uniquely designed combination of urethane foam (soft PU) rubber and steel rollers have superior grip for sharp, consistent paper folding.
- The fold roller system employs helical gears for quiet operation and flexible cross couplings for quality folding.
- The operator's screen indicates the required fold roller gap adjustment. The operator then simply inserts the indicated number of sheets.

**LCD Touch-Screen**



Roller Gap Set-up Screen      Fold Pattern Set-up Screen

- The large LCD touch-screen is provided for operator convenience.
- The roller gap set-up screen indicates the number of sheets to be inserted for roller gap adjustment.
- ※3 17 fold patterns can be set-up on the fold pattern set-up screen.
- Fine-adjustments are simple and easy.
- Forward and reverse inching simplify jam clearance.

※3 14 fold patterns can be set-up on the AFC-544AKTSC.

**Suction Head**



- Two cylinder suction head system provides accurate sheet separation for high speed feeding.
- Innovative suction head allows smooth feeding without double feeding even with recycled papers.

**Feed Rotor**



- Suction angle can be adjusted for various sheet types.
- The feed rotor employs high quality polyurethane to prevent sheet scratching or glittering.
- Maximum feeding speed is 35,000 sheets/hr. (A4 / 8.5" x 11"-parallel fold) or 43,000 sheets/hr. (A5 / 5.5" x 8.5"-parallel fold).

**AUTO** Side Lay Guide

**Side Lay Guide**



- The side lay guide is coated with a special anti-static plating.

### ■ Gate Fold Buckle : GFB-54N



- The optional gate fold buckle provides for precise, accurate gate folding. The gate fold buckle can be set up quickly, with no special skill, and provides increased versatility and profitability.

### ■ Extension Table



- With the extension table and suction head stay, up to 1,100 mm (43.3") long sheet can be loaded for gate folding operation.

### ■ Gluing Unit : CGU-50



- Folding, gluing, and edge trimming operations are performed efficiently. The gluing unit CGU-50 can produce 8-page or 12-page glued booklets.
- The amount of glue can be adjusted depending on the dot size of glue.
- The computer controlled gluing unit ensures neatly finished booklets.
- The glue is suitable for recycling.

### ■ Strip Trim Device : AF-ST5



- Strip trimming is available for multiple-up jobs with slitter.

### ■ Center-Cut & Edge-Trim Device : CGU-T54



- The CGU-T54 can trim the edge of an 8-page or 12-page folded signature.

### ■ Blades

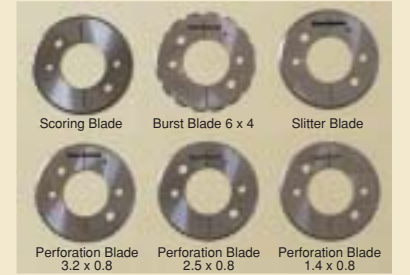

- A wide variety of optional blades are available for various applications, including slitter blades, different length perforation blades, and scoring blades.

### ■ i2i System

- The i2i system can be integrated with pre-press and printing workflow to create a comprehensive automated CIP4 bindery with the prospect of jobs passing from the eye of the creator to the eye of the beholder in a single i2i Net>Work>Flow for ultimate flexibility and efficiency in the on-demand era.

### ■ Short Conveyor : SCV-544

- <sup>※4</sup> The optional short conveyor is designed for limited space. The length is about two third of a standard conveyor.

※4 Machine Dimensions of the SCV-544 is described on the back page of this catalogue.

## ■ Press Stacker : PST-40

The PST-40 provides efficient folding operation.

- ◆ Maximum 440 mm (17.3") wide signature can be pressed.
- ◆ The first rollers remove the air and the second rollers powerfully compress the signatures for reduced bulk and tighter folds.
- ◆ The PST-40 can be started or stopped from the AFC-544AKTSC/546AKTSC control console.
- ◆ The round belt change system at the in-feed section minimizes set-up time for change of sheet size.
- ◆ The PST-40 can be operated independently of the folder for the pressing of saddle stitched booklets.
- ◆ The height of the press unit is simply adjusted by the remote controller.

#### Rollers

- The first rollers remove the air and the second rollers powerfully compress the signatures for reduced bulk and tighter folds.
- The roller gap can be adjusted by inserting the sheets to be pressed.
- A 16-page cross-fold can be compressed powerfully.

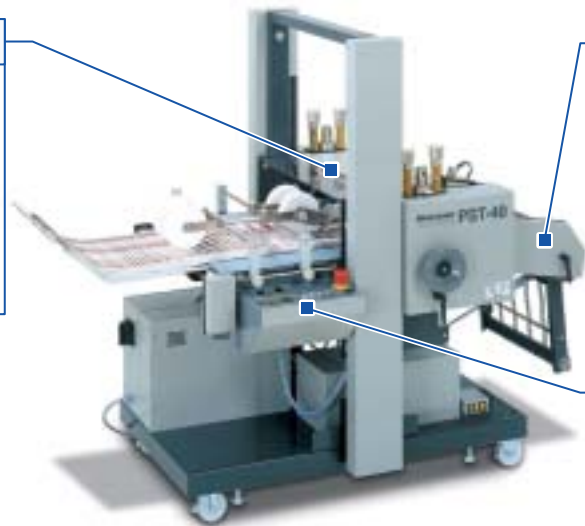

#### In-feed Section

- Multiple sheets are firmly held with the round belts and transported to the press section continuously.
- The feed angle can be adjusted to the sheet delivery from the folder.

#### Operation Panel

- Signatures can be offset separated individually or by group, depending on your job requirement.

## ■ Press Stacking & Semi-auto Bundling Unit : TST-37

This unit presses and bundles each stack to eliminate time-consuming manual steps.

- ◆ The first rollers remove the air and the second rollers powerfully compress the signatures for reduced bulk and tighter folds.
- ◆ The TST-37 can be started or stopped from the AFC-544AKTSC/546AKTSC control console.
- ◆ The round belt change system at the in-feed section minimizes set-up time for change of sheet size.
- ◆ Pressed stacks are automatically transferred to the bundling section for optimum efficiency and labor savings.

#### Operation Panel

- The lamp illuminates in the event of misfeeding or mispressing.
- The TST-37 can start or stop the operation of the AFC-544AKTSC/546AKTSC.

#### Bundling Unit

- The bundling unit is manually operated so that the stack size and bundling timing can be set according to the folding speed.
- For operator convenience, the folded sheets are always positioned at the center of the bundling section, and the plastic tape is prepared automatically.

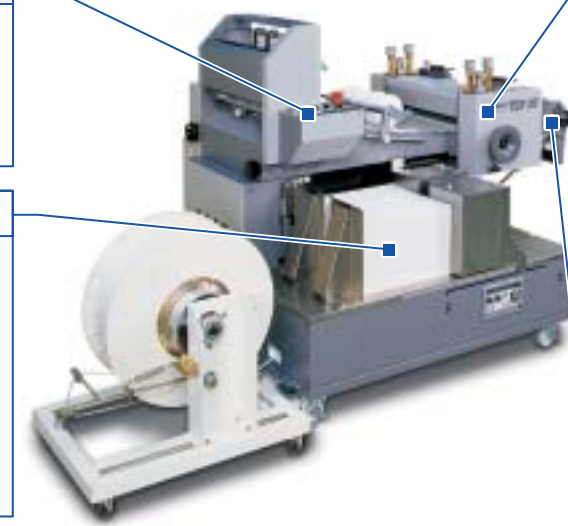

#### Rollers

- The first rollers remove the air and the second rollers powerfully compress the signatures for reduced bulk and tighter folds.
- Even a 16-page cross-fold can be compressed powerfully.
- The roller gap can be easily adjusted by inserting the sheets to be pressed.

#### In-feed Section

- The feed angle can be adjusted to the sheet delivery from the folder.

### PST-40 Major Specifications

Model	Press Stacker		Main Body Fixing Method	Adjustment Bolt			
Press Width	Max. 440 mm (17.3") [Without offset : 470 mm (18.5")]		Operation Panel	Caster with Stopper			
Press Length	Min. 64 mm (2.5")			Total Counter	Sheet Count / Offset Count		
Production Speed	Depends on fold device.		Voltage / Frequency	Preset Counter	Setting of the Number of Offset Sheets (0 to 9999)		
Roller Speed	Max. 210 m/min. (826.8"/min.)			Single Phase 200 / 220 / 230 V, 50 / 60 Hz			
In-feed Section	Belt Change System		Power Consumption	300 W, 50 Hz / 310 W, 60 Hz			
Offset	Number of Offset Sheets	1 sheet per setting (0 to 9999 sheets) or All		When Operating	When Folded	1,200(W) x 795(D) x 1,230(H) mm (47.3" x 31.3" x 48.5")	
	Offset Amount	30 mm (1.1")			When connecting to the parallel folding exit section :	1,230(W) x 795(D) x 1,230(H) mm (48.5" x 31.3" x 48.5")	
Press	Air Remove Roller	Gap is adjustable by inserting the instructed number of sheets.		Machine Dimensions	[When pulling out the receiving tray : 1,540(W) mm (60.7")]		
	Press Roller	Pressure Welding (Gap is adjustable by inserting the instructed number of sheets.)			When connecting to the cross folding exit section :	1,490(W) x 795(D) x 1,230(H) mm (58.7" x 31.3" x 48.5")	
Conveyor	Model	Horizontal Delivery Conveyor		Machine Weight	[When pulling out the receiving tray : 1,800(W) mm (70.9")]		
	Belt Speed	0 to 12 m/min. (0" to 47.2"/min.)			280 kg (617.4 lb.)		
In-feed Height	400 to 950 mm (15.8" to 37.4") [Tilt Vertical Interval 240 mm (9.4")]						
Main Body Lift	Moves up and down by a motor.						

### TST-37 Major Specifications

Model	Press Stacking & Semi-auto Bundling Unit		Stack Capacity Set-up	Setting by press guide position.		
Signature Size	Max. 370(W) x 260(L) mm (14.5" x 10.2") Min. 210(W) x 140(L) mm (8.3" x 5.6")		Transfer to Bundling Section	Preset number of sheets setting on the folder are transferred to the bundling section when operating with the folder.		
Production Speed	10,000 sheets/hr.		Compression Before Bundling	Operation After arriving at set-up stack capacity, sheet feeding of the folder is stopped to transfer.		
Roller Speed	Max. 180 m/min. (708.7"/min.)		Bundling	Transfer Position	Folded sheets are automatically positioned at the center of the bundling section.	
In-feed Section	Belt Change System			Compression Power	About 200 [N] (About 20 [Kgf])	
Press	Air Remove Roller	Gap is adjustable by inserting the instructed number of sheets.		Operation Panel	Unit Semi-Automatic	
	Press Roller	Pressure Welding (Gap is adjustable by inserting the instructed number of sheets.)			Bundle	PP Band 12(W) mm (0.47")
Conveyor	Operation	Intermittent operation only at in-feed time.		Voltage / Frequency	Total Counter / Error Lamp (No wrapping paper, Conveyor motor lock, Mis-transfer to bundling section, Mis-compression before bundling)	
	Belt Speed	0 to 12 m/min. (0" to 47.2"/min.)			Power Consumption	3-Phase 200 / 220 V, 50 / 60 Hz   Single Phase 220 / 230 / 240 V, 50 / 60 Hz (for Europe)
In-feed Height	440 to 680 mm (17.4" to 26.7")		Machine Dimensions	1.2 kW, 50 Hz / 1.1 kW, 60 Hz   3.0 kW, 50 / 60 Hz (for Europe)		
Wrapping Paper Thickness	1 to 2.5 mm (0.04" to 0.09")			[Separate Reel : 665 x 460 x 525 mm (26.2" x 18.2" x 20.7")]		
Wrapping Paper Pile Height	45 mm (1.7")		Machine Weight	370 kg (815.9 lb.) [Separate Reel : 30 kg (66.2 lb.)]		
Stack Capacity	600 sheets (64 gsm, 16-page cross fold) (With attachment : 150 sheets)					

AFC-544AKTSC/546AKTSC Major Specifications			
Machine Structure	AFC-544AKTSC	4KTT (4 Buckles+Fold Knife+2 Buckles Below Knife)	
	AFC-546AKTSC	6KTT (6 Buckles+Fold Knife+2 Buckles Below Knife)	
Max. Sheet Size	540(W) x 750(L) mm (21.2" x 29.5") [1,100(L) mm (43.3") with optional extension table]		
Min. Sheet Size	128(W) x 148(L) mm (5.1" x 5.9") [Side Lay Guide Minimum Set Position : 74(W) mm (3.0")]		
Sheet Weight Range	35 to 220 gsm		
Buckle Fold Length	AFC-544AKTSC	1st Buckle	30 to 450 mm (1.2" to 17.8")
		2nd to 4th Buckle	30 to 360 mm (1.2" to 14.1")
		K1 / K2 Buckle	30 to 150 mm (1.2" to 5.9")
	AFC-546AKTSC	1st Buckle	30 to 450 mm (1.2" to 17.8")
		2nd to 6th Buckle	30 to 360 mm (1.2" to 14.1")
		K1 / K2 Buckle	30 to 140 mm (1.2" to 5.5")
Knife Fold Size	Max. 540(W) x 350(L) mm (21.2" x 13.7") [Knife Length : 360 mm (14.1")] Min. 160(W) x 30(L) mm (6.3" x 1.2") [190(W) mm (7.5") with automatic set-up]		
Feeding Mechanism	Air Suction Rotor & 2 Cylinder Separator Head (Feed interval and suction time are adjustable.)		
Maximum Pile Height	AFC-544AKTSC	Max. 650 mm (25.5") [within 250 kg (551.3 lb.)]	
	AFC-546AKTSC	Max. 740 mm (29.1") [within 250 kg (551.3 lb.)]	
Belt Speed	50 to 230 m (54 to 250 yd.)/min. [Knife Fold : 180 m (196 yd.)/min.]		
Production Speed	35,000 sheets/hr. [A4 (8.5" x 11")-Parallel Fold] 14,000 sheets/hr. [500(W) x 700(L) mm (19.7" x 27.6")-8-page Cross Fold]		
Standard Fold Roller	Combination of Urethane Foam (soft PU) Rubber and Steel Roller Side cut blades can be attached to the roller.		
Roller Gap Adjustment	Insert the instructed number of sheets into the gap adjust lever.		
Bursting	Cut 6 mm (0.24"), Blank 4 mm (0.16")		
Perforation	Cut 2.5 mm (0.1"), Blank 0.8 mm (0.03") [Option : Cut 3.2 mm (0.13"), Blank 0.8 mm (0.03") / Cut 1.4 mm (0.06"), Blank 0.8 mm (0.03")]		
	Min. Perforation Distance : 40 mm (1.58") [Min. Distance from Sheet Edge : 12 mm (0.48")]		
Scoring	Scoring Width : About 1 mm (0.04") (Depends on sheet type)		
Cutters	Standard : 1 Burst Blade, 2 Perforation Blades / Max. 12 blades can be attached.		
Automatic Setup	Side Lay Guide, 1st to 4th Buckle [AFC-544AKTSC] / 1st to 6th Buckle [AFC-546AKTSC], Knife Stopper, Knife Guide (Front / Rear), K1 / K2 Buckle Below Knife		
Automatic Setup Accuracy	Setting Dimension : ±1 mm / Round Accuracy : ±0.1 mm		
Deflectors	1st to 4th Buckle	AFC-544AKTSC	Buckle Stopper and Deflector
	1st to 6th Buckle	AFC-546AKTSC	Buckle Stopper and Deflector
	K1 / K2 Buckle (Below Knife)	Buckle Stopper and Deflector	
Fold Patterns	AFC-544AKTSC	Parallel Fold, Short Fold, Open Gate Fold, Accordion Fold, Zigzag (4 panel) Fold, Zigzag (5 panel) Fold, Letter Fold, Double Parallel Fold, 8-page Cross Fold, 12-page Cross Fold, DL Fold (Letter / Accordion), Zigzag Cross Fold, 16-page Transformation Fold	
	AFC-546AKTSC	Zigzag (6 panel) Fold, Zigzag (7 panel) Fold, Roll Fold,	
	AFC-546AKTSC Only	Zigzag (6 panel) Fold, Zigzag (7 panel) Fold, Roll Fold,	
Job Memory	100 Jobs		
Vacuum Pump	Flow	40 m <sup>3</sup> /hr.	
	Voltage / Frequency	3-Phase ∇ 230 / Y400 V ± 10 % 50 / 60 Hz	
	Power Consumption	1.8 kW / 2.2 kW (50 / 60 Hz)	
Voltage / Frequency	3-Phase 200 / 220 / 400 V, 50 / 60 Hz		
Rated Current	AFC-544AKTSC	3-Phase 200 V, 50 / 60 Hz, 9.8 A	
		3-Phase 220 V, 50 Hz, 10.0 A / 60 Hz, 11.3 A	
		3-Phase 400 V, 50 Hz, 5.3 A	
	AFC-546AKTSC	3-Phase 200 V, 50 Hz, 9.0 A / 60 Hz, 11.4 A	
		3-Phase 220 V, 50 / 60 Hz, 8.6 A	
		3-Phase 400 V, 50 Hz, 5.0 A	
Power Consumption (Including Pump)	AFC-544AKTSC	3-Phase 200 V, 50 Hz, 2.7 kW / 60 Hz, 3.1 kW	
		3-Phase 220 V, 50 Hz, 3.0 kW / 60 Hz, 3.8 kW	
		3-Phase 400 V, 50 Hz, 2.8 kW	
	AFC-546AKTSC	3-Phase 200 V, 50 Hz, 2.7 kW / 60 Hz, 3.6 kW	
		3-Phase 220 V, 50 Hz, 2.8 kW / 60 Hz, 3.4 kW	
		3-Phase 400 V, 50 Hz, 2.8 kW	
Heat Output	880 kcal		
Motors	0.75 kW x 1 / 0.2 kW x 2 / 40 W x 1 / 0.2 kW x 1 (Servo)		
Machine Dimensions	AFC-544AKTSC	2,735(W) x 1,005(D) x 1,535(H) mm (107.7" x 39.6" x 60.5")	
	AFC-546AKTSC	2,780(W) x 1,005(D) x 1,662(H) mm (109.5" x 39.6" x 65.5")	
Installation Space	5,100(W) x 3,709(D) mm (200.8" x 146.1")		
Noise Level	82 dB [Peak Level : 8-page cross fold with 700 x 550 mm (27.6" x 19.7"), 64 gsm sheet]		
Machine Weight	AFC-544AKTSC	Main Body : 880 kg (1,940.4 lb.), Conveyor : 50 kg (110.3 lb.), Vacuum Pump : 50 kg (110.3 lb.), Transformer : 70 kg (154.4 lb.)	
	AFC-546AKTSC	Main Body : 940 kg (2,072.7 lb.), Conveyor : 50 kg (110.3 lb.), Vacuum Pump : 50 kg (110.3 lb.), Transformer : 70 kg (154.4 lb.)	
Temperature & Humidity	Temperature 0°C to +45°C, Humidity 20% to 75%RH		

Machine Dimensions Unit : mm (inch)

Parallel Fold Height = 1,662 (65.5") [※1,535 (※160.5")]

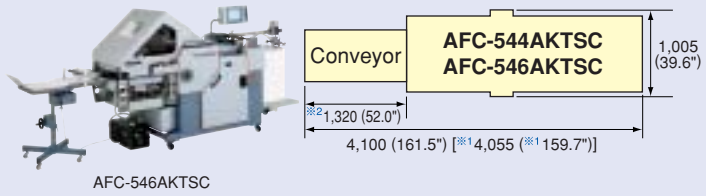

8-page Cross Fold Height = 1,662 (65.5") [※1,535 (※160.5")]

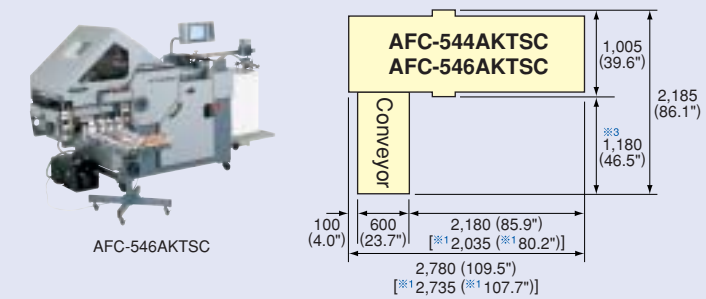

Height = 1,230 (48.5")

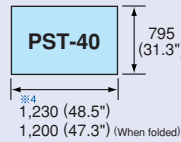

Height = 1,130 (44.5")

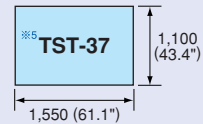

Vacuum Pump Height = 400 (15.8")

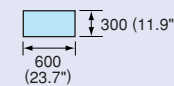

Transformer Height = 480 (18.9")

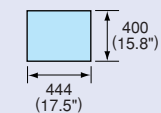

- ※1 Machine Dimensions for AFC-544AKTSC.
- ※2 Min. 630 mm (24.9") to Max. 860 mm (33.9") when connecting with the optional short conveyor SCV-544.
- ※3 Min. 480 mm (18.9") to Max. 710 mm (28.0") when connecting with the optional short conveyor SCV-544.
- ※4 Min. 1,230 mm (48.5") to Max. 1,540 mm (60.7") when connecting to the parallel folding exit section.  
Min. 1,490 mm (58.7") to Max. 1,800 mm (70.9") when connecting to the cross folding exit section.
- ※5 The separate reel will be attached to the opposite side of the in-feed section.

The machine design and specifications are subject to change without any notice.

Distributed by



Standard Finishing Systems, 10 Connector Road, Andover, MA 01810 (877) 404-4460 www.standardfinishing.com

HORIZON INTERNATIONAL, INC.

510 Kuze Ooyabu-cho, Minami-ku, Kyoto, 601-8206, Japan Phone : +81-(0)75-934-6700, Fax : +81-(0)75-934-6708, www.horizon.co.jp

