

Serial Numbers 071755 & Up

OPERATOR'S MANUAL



The Challenge Machinery Company
6125 Norton Center Drive
Norton Shores, MI 49441-6081 USA

ChallengeMachinery.com

TITAN 265 XG ***PAPER CUTTING*** ***MACHINE***

Sold and Serviced by

F.265XG-EO
May 2008

1.0 Introduction

THIS MANUAL is designed to help you get the most from your Challenge equipment. Keep this manual in a safe, convenient place for quick reference by operators and service personnel.

! CAUTION

SAFETY ALERT! This symbol means **CAUTION: Personal safety instructions!** Pay special attention to the instructions in bold type. Personal injury may result if the precautions are not read and followed.

READ THIS MANUAL BEFORE OPERATING! Follow precautions and instructions given and you should have years of trouble-free operation. If after reading the manual questions still remain, contact your Authorized Challenge Dealer.

FOR PARTS AND SERVICE contact the Authorized Challenge Dealer from whom you purchased your machine. Use the illustrations and parts lists at the back of this manual to identify the correct parts needed. Always give the **SERIAL NUMBER** and **MODEL** of your machine to insure the correct parts are sent as soon as possible.

Take a few minutes right now to **RECORD YOUR MACHINE SERIAL NUMBER** in the space provided on the front cover of this manual. Also be sure to fill out the warranty card accompanying your machine and return it **DIRECTLY TO CHALLENGE**.

If you bought a used machine, it is important to have the following information on record at Challenge. Copy this page, fill in the information and send it care of The Challenge Service Department, Norton Center Drive • Norton Shores • MI 49441-6081.

CHALLENGE MODEL	SERIAL NUMBER	
ATTN	COMPANY	
ADDRESS		
CITY	STATE/PROVINCE	ZIP
PHONE	DATE INSTALLED	
DEALER NAME & CITY		

*** WARRANTY INFORMATION ***

It is very important that you read and understand the conditions outlined in the *Warranty Information Sheet* attached to the outside of the shipping container of your machine.

The *Warranty Information Sheet* must be filled out completely and returned to THE CHALLENGE MACHINERY COMPANY in order for the warranty to be issued for this machine.

TABLE OF CONTENTS

1.0 Introduction	2
2.0 Safety	5
2.1 Precautions	5
2.2 Power Lockout Procedure	5
2.3 Warning Label Definitions	6
3.0 Packing List	8
Optional Items	8
4.0 Specifications	9
5.0 Installation & Setup	10
5.1 Inspecting Shipment	10
5.2 Uncrating	10
5.3 Cleaning	11
5.4 Fitting Through Narrow Door	11
5.4.1 Removing the Extension Tables	11
5.4.2 Removing the Table	12
5.4.3 Removing the Electric Eyes	14
5.4.4 Removing the Footswitch	14
5.4.5 Attaching the Table	14
5.4.6 Attaching the Extension Tables	14
5.4.7 Attaching the Electric Eyes	15
5.4.8 Attaching the Footswitch	15
5.5 Hydraulic System Check	15
5.6 Optional False Clamp Plate	16
5.7 Power Hook-Up	17
5.7.1 Single Phase Hook-Up	18
5.7.2 Three Phase Hook-Up	18
5.8 Line Light	19
6.0 Operation	20
6.1 Power - Main Power Switch	20
6.2 Start Up	20
6.3 Making a Cut	21
6.4 Air Table Option	21
6.5 Jogging Aid	21
6.6 Adjusting the Clamp Pressure	22
6.7 Pre-Clamping	22
6.8 Knife Change Alarm and Lubrication Alarm	23
6.9 Electric Eyes	23
6.10 False Clamp Plate	23
6.11 Display Panel	23
6.12 Definition of Keys	23
6.12.1 Backgauge Glide Control	23
6.12.2 IN/MM Key	24
6.12.3 Air Table ON/OFF Key	24
6.12.4 Send Key	24
6.12.5 Push-Out Key	24
6.12.6 Clear Key	24
6.12.7 Enter Key	24
6.12.8 Priority Add (X/Y) Key	25
6.12.9 Soft Keys	25
6.12.10 Arrow Keys	25
6.12.11 Contrast Control	25
6.13 Manual Backgauge Control	25
6.13.1 Backgauge Glide Control	25

1.0 Introduction

6.13.2 Backgauge Control Knob.....	25
6.13.3 Backlash Indicator.....	25
6.14 Send Mode.....	26
6.14.1 Entering Math.....	26
6.14.2 Entering Fractions.....	26
6.15 Repeat Mode.....	26
6.16 Maintenance Mode.....	27
6.16.1 Language.....	27
6.16.2 Parameters.....	27
6.16.3 Diagnostic.....	29
6.17 Job Mode.....	30
6.17.1 Lock/Unlocking a Job.....	30
6.17.2 Copying a Job.....	30
6.17.3 Erasing a Job.....	30
6.17.4 Creating a New Job.....	30
6.17.5 Editing an Existing Job.....	35
6.17.6 Running a Programmed Job.....	36
6.17.7 Exiting a Job.....	36
6.18 An Example Job.....	36
6.19 Operating Tips.....	37
7.0 Knife Installation/Changing.....	38
7.1 Knife Removal.....	38
7.2 Knife Installation.....	40
7.3 Knife Care Tips.....	41
7.3.1 Knife Blade Life.....	41
7.3.2 Cutting Stick.....	42
7.3.3 Bevel Angle.....	42
7.3.4 Helpful Suggestions.....	42
7.3.5 Knife Care.....	42
8.0 Safety Systems Test.....	44

2.0 Safety

2.1 Precautions

- This machine is designed for one-person operation. Never operate the machine with more than one person.
- Safe use of this machine is the responsibility of the operator. Use good judgment and common sense when working with and around this machine.
- Read and understand all instructions thoroughly before using the machine. If questions remain, contact the dealer from which you purchased this machine. Failure to understand the operating instructions may result in personal injury.
- Only trained and authorized people should operate this machine.
- Do not alter safety guards or devices. They are for your protection. Severe personal injury may result.
- Disconnect power before cleaning or performing maintenance. See Section 2.2 Power Lockout Procedure.
- Observe all caution labels on this machine.
- Be sure the cutter is properly grounded.
- Be sure there is sufficient power to operate the cutter properly.
- Observe all caution plates mounted on this cutter.
- Keep foreign objects off table and away from cutter blade.
- **BE EXTREMELY CAREFUL** when handling and changing the cutter knife. Severe lacerations or dismemberment could result from careless handling procedures.
- Keep the floor around the cutter free of trim, debris, oil and grease.
- When replacing hydraulic parts, loosen the connections slowly to release pressure. Never loosen connections with the machine running.
- If the cutter sounds or operates unusually, turn it off and consult the troubleshooting section of this manual. If the problem cannot be corrected, have it checked by a qualified service person.
- **CRUSH HAZARD**, keep hand and fingers from under the clamp when clamping paper. Use Jogging Aid to load paper, and use the backgauge to push paper out before unloading. **DO NOT REACH UNDER THE KNIFE AND CLAMP AREA!**

2.2 Power Lockout Procedure

For maximum safety when making adjustments or repairs to your machine, be sure to lock out the main power control switch to which the machine is connected. The switch should be moved to the OFF position and a padlock placed in the loop. The key should be held by the person servicing the machine.

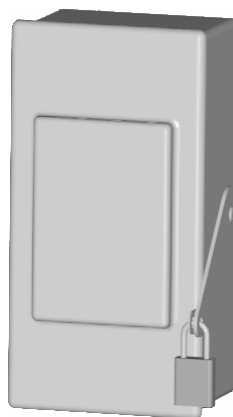

Figure 1

2.3 Warning Label Definitions

The following warning labels are found at various locations on your machine. Read and understand the meaning of each symbol. If a label is lost from the machine, it should be replaced.



HAZARDOUS AREA

Disconnect power before cleaning, servicing, or making adjustments not requiring power. Do not alter safety guards or devices; they are for your protection. Replace all guards. Do not operate with any guards removed.



SHOCK HAZARD

Disconnect power before removing cover. Replace cover before operation.



SHOCK HAZARD

Disconnect power before removing cover. Replace cover before operation.



SINGLE OPERATOR

Do not operate with more than one person.

!OJO!



CAUTION This Este simbolo de alerta de seguridad significa ¡ OJO ! - INSTRUCCIONES DE SEGURIDAD PERSONAL. Lea las instrucciones porque se refieren a su seguridad personal. Fall de obedecer las instrucciones que siguen podria resultar en lesiones corporales.

- Esta maquina, junto con sus mecanismos de seguridad, esta disenada para ser manejada por
- **UNA SOLA PERSONA** a la vez. Jamas debe ser manejada por mas de una persona al mismo
- tiempo.
- La seguridad es la responsabilidad del operario que usa esta maquina.
- **LEA DETENIDAMENTE** el manual de instrucciones y las **PRECAUCIONES DE SEGURIDAD** antes de poner a funcionar la cortadora. Pidale a su supervisor una copia.
- El manejo de la guillotina debe estar exclusivamente a cargo de personal entrenado y autorizado para ello.
- **NO MODIFIQUE LOS MECANISMOS DE SEGURIDAD**, estan ahi para su proteccion no deben ni modificarse ni quitarse.
- **DESCONECTE LA CORRIENTE ELECTRICA** antes de proceder a hacerle servicio de limpieza, engrasar, o de hacer ajustes que no requieren corriente. Trabe el interruptor en la posicion **OFF** (apagado); vea "Procedimiento para cortar la corriente electrica" al pie de esta pagina.
- Eche llave a la guillotina y quite la llave cuando la maquina no esta en operacion; vea "Corriente electrica".
- Asegurese de que la guillotina este debidamente a tierra. Vea "Conexion de la fuerza electrica".
- Verifique el voltaje y asegurese de que este sea suficiente para el debido funcionamiento de la guillotina.
- Preste atencion a todas las placas con advertencias instaladas en esta guillotina.
- No permita que objetos estranos esten en la mesa o cerca de la cuchilla cortadora.
- **TENGA SUMO CUIDADO** al tocar y cambiar la cuchilla. Heridas severas y hasta desmembramiento pueden resultar del manejo sin cuidado o negligente.
- El suelo alrededor de la guillotina debe mantenerse despejado y libre de recortes, desperdicios, aceite y grasa.
- Al haber la necesidad de reemplazar partes hidraulicas, afloje todas las conexiones poco a poco para dejar escapar la presion. Jamas debe aflojarse conexiones mientras la maquina este
- andando.
- Si la guillotina empezara a sonar o trabajar diferentemente a lo acostumbrado, desconectela y consulte la seccion "Troubleshooting" (Reparador) de este manual. Si no es posible corregir el problema, llame a su servicio autorizado para que le examinen la maquina.
- **PELIGRO DE MACHUQUE** - Mantenga manos y dedos fuera de la agarradera mientras sujeta el papel. Use el calibrador trasero y su rueda de mano para empujar el papel cortado. **NO PONGA SUS MANOS BAJOLA CUCHILLA O AREA DE LA AGARRADERA.**
- **NO OPERE SIN LAS GUARDAS PROTECTORAS!**

¡ OJO ! PRECAUCION - Como proceder para desconectar la corriente electrica.

Para maxima seguridad durante ajustes y reparaciones de su maquina, verifique bien que el interruptor principal de control de corriente al cual la maquina esta conectada, este desconectado. El interruptor deba ser puesto en la posicion "OFF" (desconectado) y se debe poner un candado en la anilla. La llave del candado debe ser guardada por la persona que estara efectuando los trabajos de servicio o de reparacion en la guillotina.

Desconecte la corriente electrica antes de proceder a hacer cualquier ajuste o reparacion o de efectuar el engrase en cualquier maquina.

3.0 Packing List

Part No.	Description	Qty.
2263-2	Knife	2
4165	Cutting Stick (in addition to one installed in machine)	3
F.265XG-EO	Operator's Manual	1
A-12608-4	Jogging Aid	1
20-2150-4	Tool Kit	1
H-6918-608	Knife Bolts, 3/8 – 16 x 1"	6
8815	Knife Washers, Special	6
5064	Cutting Stick Puller	1
44183	Knife Lifter Assembly	1
W-141	1/8" Allen Wrench	1
W-137	5/32" Allen Wrench	1
W-164	5/16" Hex 'T' Wrench	1
W-158	3/8 x 5/16" Wrench	1

Optional Items

Part No.	Description	Qty.
44027	False Clamp Plate	
4165	Cutting Stick	
2263-3	High Speed Steel Knife	
41058	Waste Wagon	

4.0 Specifications

Description	Inch Units	Metric Units
Cutting Width	26 ½"	67.3 cm
Minimum Cut*	5/8"	16 mm
Clamp Opening	4"	10.2 cm
Table Space		
Front:	24 ¼"	62 cm
Back:	28"	71 cm
Dimensions		
Table Height	36"	91 cm
Overall Height	59"	150 cm
Overall Length**	69 ½"	176.5 cm
Overall Width	54"	137.2 cm
Approx. Net Weight	1780 lbs	807 kg
Approx. Shipping Weight	2020 lbs	916 kg
Electrical		
208/230 Volts, 25 Amps, 3 Phase, 60 Hz, AC. Service size 30 Amps		
<i>Optional:</i>		
208/230 Volts, 30 Amps, 1 Phase, 60 Hz, AC. Service size 40 Amps		
208/230 Volts, 30 Amps, 1 Phase, 50 Hz, AC. Service size 40 Amps		
380/415 Volts, 15 Amps, 3 Phase, 50 Hz, AC. Service size 20 Amps		
Sound Emission		
A-weighted sound pressure level measured in an enclosed room at operator level (6 feet/183 cm):		
Machine in idle state:		60 dB
Machine cycling without cutting paper:		70 dB

*With false clamp plate attached, minimum cut is 1-7/8" (48 mm).

**With table, electric eyes, and footswitch removed, can be fit through a 32" (81.3 cm) door opening.

Challenge reserves the right to make changes to any product or specification without notice and without incurring responsibility to existing units.

5.0 Installation & Setup

5.1 Inspecting Shipment

This machine has been carefully packed to prevent damage during shipment. However, claims for damage or loss are the responsibility of the recipient. Inspect all shipments as soon as they are received. If there is any noticeable damage, note it on the freight bill. Visual and/or hidden damage must be reported to the claims department of the carrier within 15 days. Contact your dealer if you need any assistance. Check the contents of the box against the packing list on page 8. Make sure there are no missing items.

5.2 Uncrating

The Titan 265 weighs approximately 1780 lbs (807kg). DO NOT risk personal injury or damage by attempting to move machinery with makeshift equipment or inadequate manpower. This machine is shipped on a wooden skid and enclosed in a protective, corrugated top. The machine is secured in place with (4) lag screws. All accessories are packed in a separate box.

Remove the carton by removing the nails or staples holding it to the skid and lift it straight up over the cutter. If you don't have the ceiling clearance to do this, carefully slit the carton down the side and then unwrap it from around the cutter. Remove the accessory box. Remove the lag screws that secure the machine to the skid. Cut shipping straps on the hydraulic reservoir and remove wood spacer from under reservoir.

The machine may then be removed from the skid. A fork-lift may be used if the forks will extend to the back of the machine base. Raise the machine enough to create a small clearance between the skid and machine. Make sure the forks engage the fork pockets found beneath the base. Remove the skid.

 CAUTION DO NOT place hands under machine at any time during skid removal. Place the machine on the ground and readjust placement of the forks for safe transport to its destination.

Alternately, the following method may be used to lift the machine from the skid. Remove the table extensions (page 11) and the lower front cover. Using lifting straps rated at 2000 lbs. or more, wrap the straps around the machine base from front to back on each side of the table as shown in Figure 2 & Figure 3. Hoist the machine and remove its skid.

IMPORTANT! Do not lift the machine by any portion of the table. The aluminum table may pull from the base and strip its mounting threads. Injury may result.

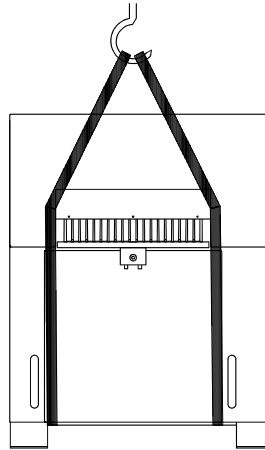

Figure 2

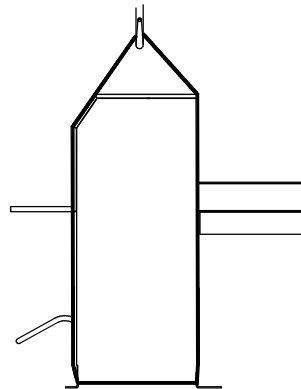

Figure 3

5.3 Cleaning

After unpacking, wipe down all machine panels and clean the table surface. The display screens and control console should be cleaned using a mild water-based soap solution. **DO NOT use petroleum or oil based solvents as they will damage the display screens and control console.**

5.4 Fitting Through Narrow Door

As shipped, the Titan 265 cutter will not fit through an opening less than 54" (137 cm). With the extension tables removed, it will fit through a 46-1/2" (118 cm) opening. With the table and electric eyes removed, it will fit through a 31" (79 cm) opening.

5.4.1 Removing the Extension Tables

Make sure power is disconnected from the machine. Remove the front table plate (Figure 4) by removing the hex nuts. Remove the extension table hardware and remove extension tables.

NOTE: There may be shims located between the extension tables and the extension table brackets. These are used for leveling the extension tables at the factory. Take note as to where they are located so they can be placed in the proper position when reattaching the extension tables later.

5.0 Installation & Setup

Now remove the two extension table support brackets (Figure 4).

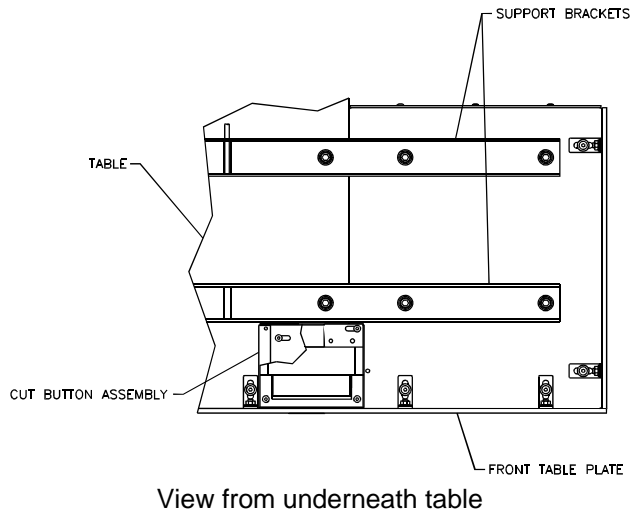

Figure 4

5.4.2 Removing the Table

Make sure the knife has been removed from the machine and that the knife and clamp are in the “up” position. If they are not, read the Power Hookup Section (page 17) to connect power to the machine. Turn on the power using the red and yellow main power switch, and press the CLEAR button. This will preset the backgauge and send the knife and clamp up.

Turn off the machine and disconnect the power.

Make sure the extension tables have been removed (page 11). Remove the 2-hand button controls. Remove the sheet metal covers from the rear of the table. Remove the backgauge motor cover, the lower back panel, and the lower front cover of the machine.

Unplug the cable to the encoder at the back of the machine (Figure 5). Remove the motor junction box cover and disconnect the wires to the motor (Figure 5). Remove the leadscrew cover and the nylon tyrops that are attached to the bottom of the table. The motor wires and encoder wires should now be free from the table.

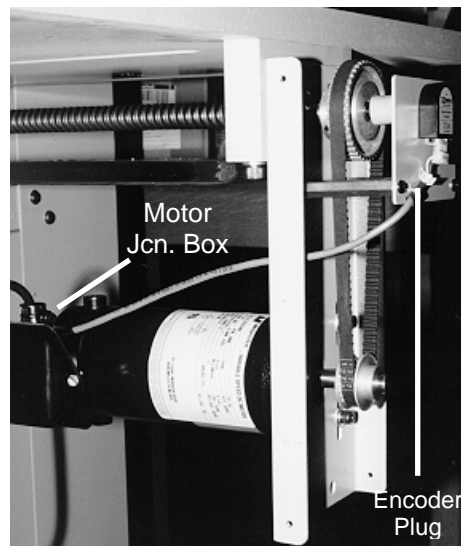

Figure 5

Remove the preset board assembly from the bottom of table (Figure 6).

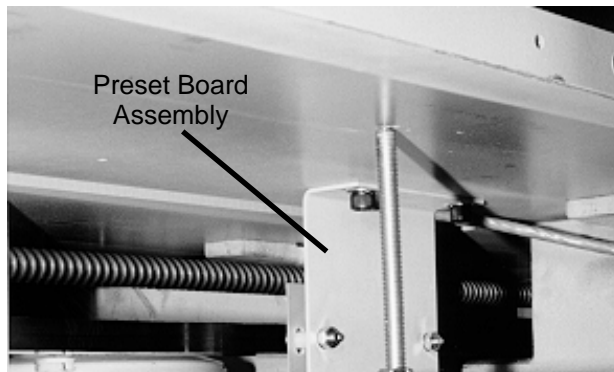

Figure 6

Open the top hood and loosen the jam nut on left hand side guide support screw and turn it in a few turns for clearance, then remove the left and right side guides as shown in Figure 7 & Figure 8.

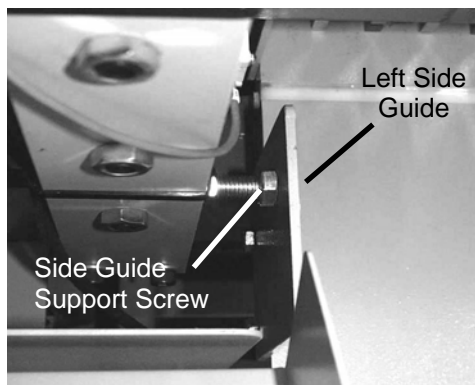

Figure 7



Figure 8

Remove the two taper pins from the bottom side of the table by tightening the jam nut on the taper pin. Then remove the four screws that mount the table to the base. **CAUTION: the table assembly is very heavy and requires at least four people to remove.** Pull the table out towards the back of the machine.

5.4.3 Removing the Electric Eyes

Make sure power is disconnected from the machine. Open top cover. Remove the four hex-head screws for each electric eye assembly from the inside of the machine. By sliding some of the slack in the cable through the side of the machine, the eye assemblies can be set on the machine. If it is necessary to completely remove the eyes from the machine, the wires must be disconnected from the power panel.

5.4.4 Removing the Footswitch

Make sure power is disconnected from the machine. Remove lower front cover. Remove the two screws that mount the footswitch bracket (Figure 9). Lay footswitch assembly inside the machine.

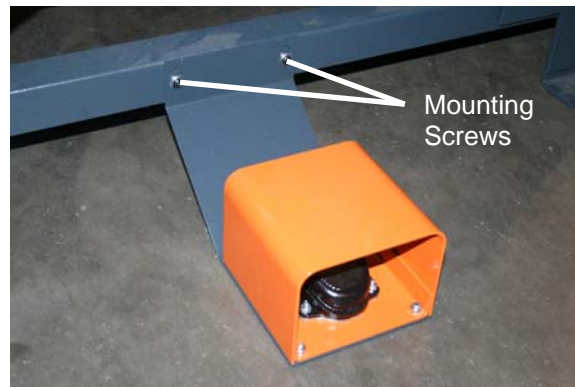

Figure 9

5.4.5 Attaching the Table

Set the table in position, and start its front two mounting screws. Then start the rear two mounting screws. Replace the two taper pins (must be snug to seat the table), and then tighten all four screws. Attach the right and left side guides then re-adjust the left hand side guide support screw until it contacts the side guide and tighten the jam nut. (Figure 7 & Figure 8 on page 13), the preset board assembly (Figure 6 on page 13), the motor and encoder wire (Figure 5 on page 12) and all guards and panels.

Once the table is installed, the backgauge squareness and accuracy must be readjusted. See the Titan 265 Technical Service and Parts manual for information on how to do this.

5.4.6 Attaching the Extension Tables

Attach the extension table support brackets to the under side of the main table as shown in Figure 10, but do not tighten screws completely. Route each cut button wire through the slots in the brackets while attaching them. Next, place any shims that were installed at the factory in the position they were in when the extension tables were removed. Lay the table extensions in place and insert the screws. Align the front edges of the tables and tighten screws. Attach the front table plate.

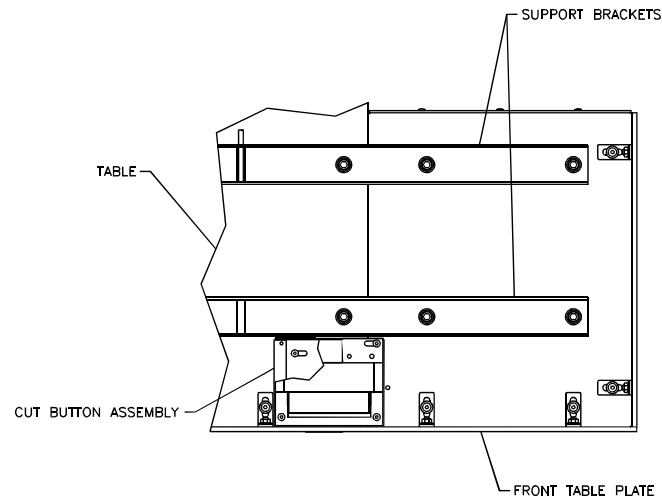
**Figure 10**

5.4.7 Attaching the Electric Eyes

Make sure power is disconnected from the machine. If necessary, connect the wires to the power panel. Attach electric eye assemblies with provided hardware, making sure that the bottom of the electric eye housings are parallel to the table. Once power is hooked up, the electric eyes should be checked for alignment. See the Titan 265 Technical Service and Parts manual for information on how to do this.

5.4.8 Attaching the Footswitch

Make sure power is disconnected from the machine. Attach the footswitch bracket using the mounting hardware (Figure 9, page 14).

5.5 Hydraulic System Check

The Titan 265 is powered by a hydraulic system consisting of an electric motor coupled directly to a hydraulic pump.

The hydraulic reservoir holds 5 gallons of hydraulic fluid. It is filled with Tellus #46 hydraulic fluid at the factory but should be checked before operation. Remove the lower rear panel cover. Check the sight gauge on the rear side of the hydraulic tank. Fluid should just be visible in the sight gauge (Figure 11, next page). Add fluid if necessary, but avoid overfilling. For more information about checking and changing the hydraulic fluid, including a cross-reference chart of approved fluids, See the Titan 265 Technical Service and Parts manual. When finished, replace the panel.

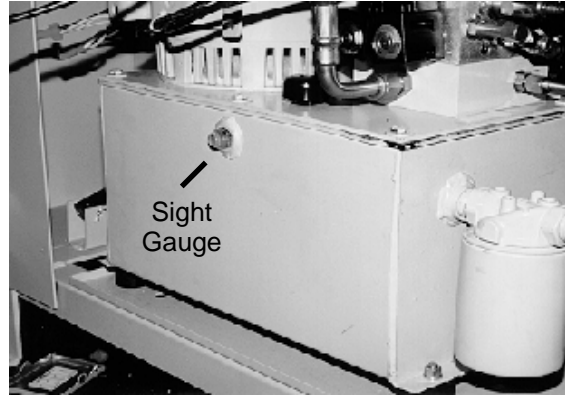

Figure 11

The hydraulic fluid should be checked weekly and changed **AT LEAST ONCE-PER-YEAR** or after every 1,000 hours of operation.

5.6 Optional False Clamp Plate

To prevent marking on pressure sensitive jobs, a false clamp plate is available as an optional item for your machine. This plate attaches to the bottom of the clamp. It is secured with (3) setscrews located in holes on the lower front face of the clamp.

To install:

1. Make sure the knife and clamp are in the up position. If they are not, turn on the power using the red and yellow main power switch. Press the CLEAR button. This will preset the backgauge and send the knife and clamp up.
2. REMOVE KNIFE. See Section 7.1 Knife Removal, page 38.
3. Turn the power off and disconnect the power cord.
4. Slide the false clamp plate under the clamp and slide the plate up into position.
5. Hold the plate in position and secure with the (3) setscrews located in the lower front face of the clamp, Figure 12.
6. A sensor detects that the false clamp is installed and the computer setting will automatically be set to ON.

NOTE: The minimum cut with the false clamp plate attached is 1-7/8”.

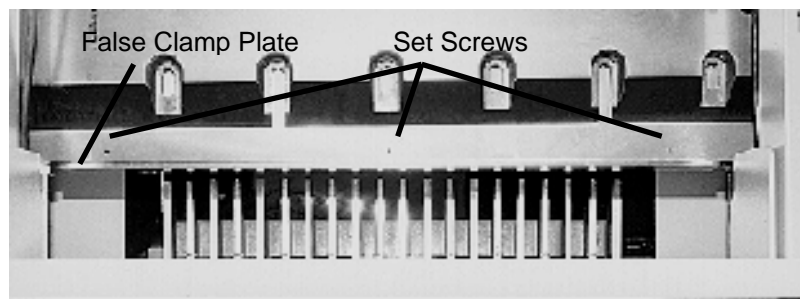

Figure 12

5.7 Power Hook-Up

For satisfactory operation, be sure that your cutter is wired for the correct phase and voltage and has adequate power. The correct electrical specifications for your machine are shown on the serial plate. Check the machine serial plate before connecting the power. For future reference, transfer this information to the front cover of this manual.

Watch Setup Voltage- Inadequate power to the cutter can be a major source of problems. Too many machines on the same circuit will reduce the power to each machine. Inadequate voltage will frequently cause overheating, loss of power, and in extreme cases, failure to operate. Test your voltage when the shop is at actual working levels. Challenge recommends a dedicated line with a lockable disconnect to provide adequate power for this machine.

CAUTION CAUTION: SHOCK HAZARD! Always disconnect power at main power panel before working on the cutter. Lock it out to prevent accidental power up. (See Power Lockout Procedure page 5).

Important: You must have an adequate size circuit and heavy enough wiring for this machine. The circuit size should be a minimum of 20% greater than the amperage rating on the machine nameplate. If a wire is run over 75 feet (23 meters), the next size wire should be used. Check local electrical codes.

Electrical Specifications for the Titan 265:

	Voltage	Amperage	Circuit Size	Wire Size
Three Ph.:	208/230 V	25 A	30 A	#10 AWG
Single Ph.:	208/230 V	30 A	40 A	#8 AWG

Check incoming voltage and position voltage selection jumper in proper location as shown in (Figure 13).

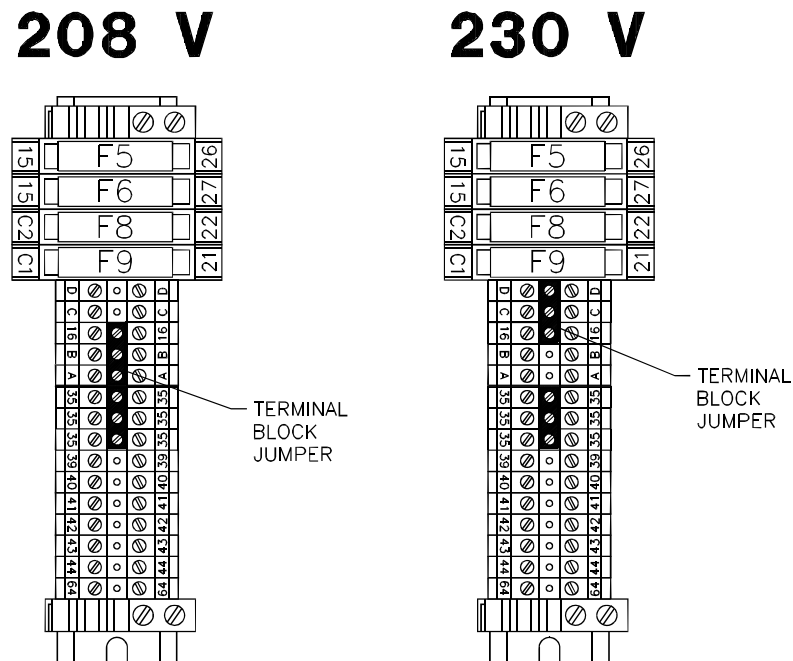

Figure 13

5.0 Installation & Setup

NOTE: The terminal block jumper must be set to the correct location according to the supply voltage of the machine. **Failure to set the terminal block jumper will cause damage to the machine!**

The power source is connected to the cutter at in the junction box located at the rear, right hand side of the machine.

5.7.1 Single Phase Hook-Up

1. Disconnect the power at the main power panel and lock it out to prevent accidental power-up. See Power Lock-Out procedure, page 5.
2. Thread the power cord through the knock-out hole in the junction box located near the floor in the lower left hand corner of the machine rear. Secure it with a conduit connector.
3. Fasten the ground lead to the ground terminal lug found in the junction box.
4. Use wire nuts to join the two power leads to the L1 and L2 leads found in the junction box.
5. Close all doors and guards, unlock the main power and switch it on. The machine should now have power.

5.7.2 Three Phase Hook-Up

1. Disconnect the power at the main power panel and lock it out to prevent accidental power-up. See Power Lock-Out procedure, page 5.
2. Thread the power cord through the knock-out hole in the junction box located near the floor in the lower left hand corner of the machine rear. Secure it with a conduit connector.
3. Fasten the ground lead to the ground terminal lug found in the junction box.
4. Use wire nuts to join the three power leads to the L1, L2 and L3 leads found in the junction box.
5. Close all doors and guards, unlock the main power and switch it on. The machine should now have power.
6. Press both cut buttons simultaneously to activate the motor and check to make sure it is turning the same direction as the arrow on the motor casing. If it isn't, disconnect the power and simply exchange any two leads of the power cord as in Figure 14 on page 18. The motor will now turn the correct direction. Double check to make sure.

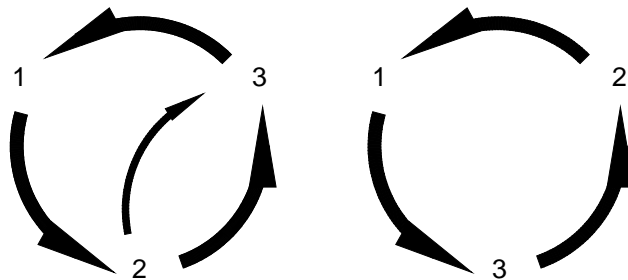

Figure 14

5.8 Line Light

The Titan 265 is equipped with two lights, which provide a line of light on the paper in the approximate location of where the paper will be cut. The lights come on when power to the machine is turned on. The light from each bulb reaches the table after passing between the knife and clamp. Each light is focused with a socket head capscrew (Figure 15).

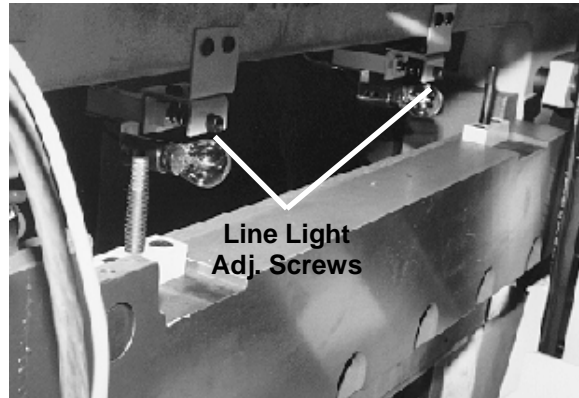

Figure 15

To Adjust:

1. Place a wide sheet of paper on the cut stick to view the line light.
2. Using a 3/16" hex allen wrench, turn one of the cap screws until you see a 1/16-1/8" beam. NOTE: it is best to start by turning the screw clockwise. If the screw turns all the way in before a line appears, begin turning the screw counterclockwise.
3. Similarly, turn the adjustment screw of the other bulb, until one continuous beam is seen across the cut stick.

⚠ CAUTION **SHOCK HAZARD!** Always disconnect power at main power panel before working on the cutter. Lock it out to prevent accidental power up. See Power Lockout Procedure, page 5.

Bulb replacement:

1. Make sure power is off (see Power Lockout Procedure, page 5).
2. Remove the old bulb by lightly pushing the bulb into the socket and turning it 1/4 turn counterclockwise. **CAUTION! If the bulb is still hot, allow a few minutes for it to cool.**
3. Insert the new bulb into the socket, push it in and twist it clockwise until the bulb locks into place.
4. Reconnect power and turn the main power switch on. Readjust the line if necessary.

6.0 Operation

IMPORTANT: DO NOT ATTEMPT TO OPERATE THE CUTTER UNTIL YOU HAVE THOROUGHLY READ AND UNDERSTAND ALL OF THE FOLLOWING INSTRUCTIONS. CALL YOUR AUTHORIZED CHALLENGE DEALER IF YOU STILL HAVE ANY QUESTIONS.

6.1 Power - Main Power Switch

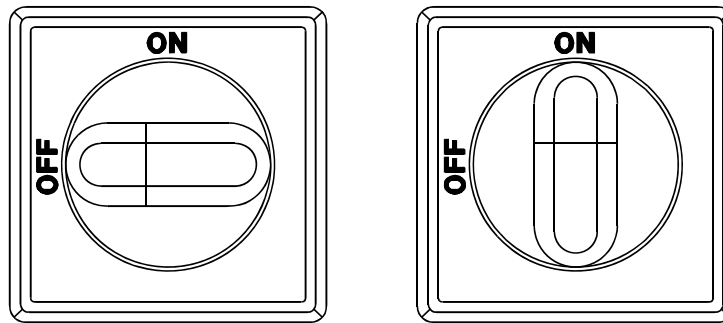

Figure 16

Power is brought to the machine when the main power switch is turned to the “ON” position (Figure 16). The display and line lights are turned on at this time.

The screen saver will activate and the line lights will shut off after 5 minutes without any activity. This shut-off time can be changed in the Parameters screen of the Maintenance Mode (see the “Operating Controls/Maintenance Mode/Parameters/Time Out” section). To restore power to the display and line lights, press any button on the keyboard.

6.2 Start Up

Once power has been turned on, the display will show the following:

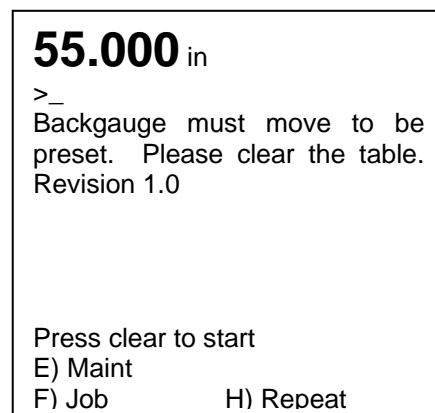
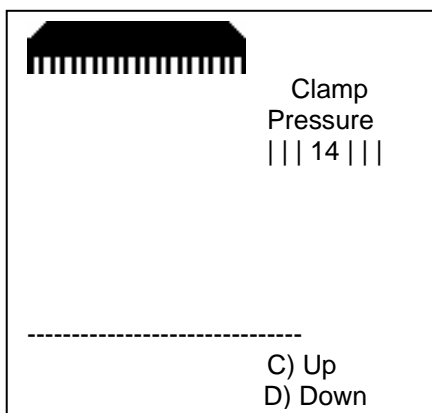

When the CLEAR key is pressed, the backgauge will move to coordinate the true position into the computer (if the knife and clamp are not in the “up” position, the display will prompt the operator to raise them by pressing the cut buttons prior to presetting the backgauge). When finished, the machine will be in “Send Mode” and the display will appear similar to the display shown next:

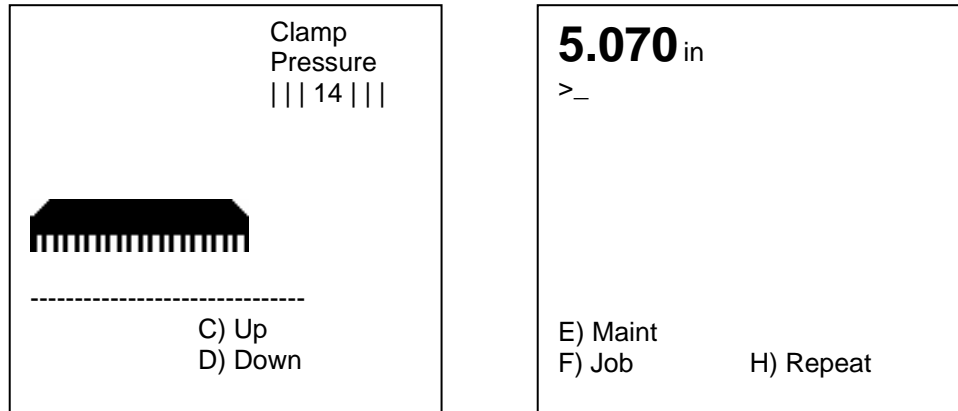

The backgauge may now be sent to a desired position by simply typing the dimension and pressing SEND (see the “Send Mode” section, page 26, for more details).

6.3 Making a Cut

Place the paper against the backgauge and left side guide. Note: if the cut will leave strips of paper less than 2-1/8” wide, place the paper against the right side guide. This will prevent the strips from getting caught in the small opening near the left side guide.

First, start the hydraulic motor by simultaneously pressing both cut buttons (located under the table at the front of the machine). Then, with the electric eyes unobstructed, make a cut by simultaneously pressing both buttons and holding them in until the knife reaches the table. If at any time during the cut cycle one or both cut buttons are released, or if the electric eyes are obstructed, the knife and clamp will immediately be sent to the up position. Once the cut cycle is complete, the hydraulic motor will continue to run until the time out period expires, or it can be shut off by pressing soft-key “B” (Motor Off) or by pressing and holding the right cut button for three seconds.

6.4 Air Table Option

Machines equipped with an air table option can have the air table feature turned on or off by pressing soft-key “D” (Air) or by pressing and holding the left cut button for three seconds.

6.5 Jogging Aid



Always remove the jogging aid from the table before making a cut.

A jogging aid is included as standard equipment with the Titan 265. This tool allows the operator to load and align paper without the need to place hands or arms under the knife or clamp.

To use, load the paper against the side and backgauge using the jogging aid (Figure 17 & Figure 18). Remove the jogging aid from the table and make the cut.



Figure 17

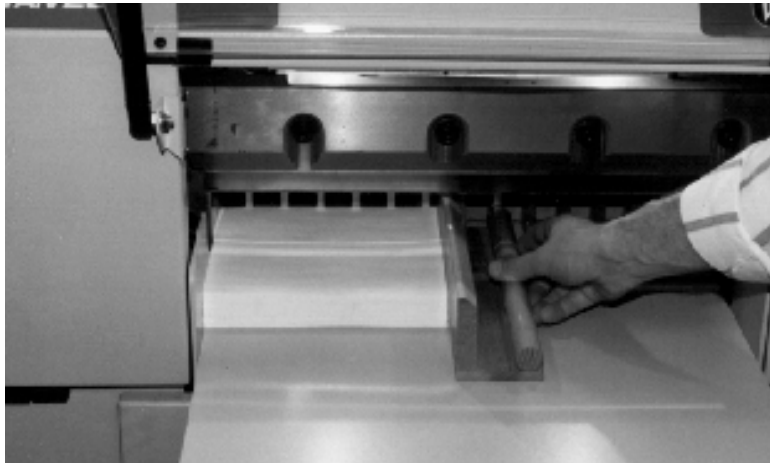

Figure 18

6.6 Adjusting the Clamp Pressure

The clamp pressure can be adjusted by pressing soft-key "C" (Up) to increase the pressure, and soft-key "D" (Down) to decrease the pressure. The pressure scale ranges from 0 to 15, 15 being the maximum.

6.7 Pre-Clamping

The Titan 265 is equipped with a low-pressure clamping feature, which allows the operator to clamp paper under low pressure before beginning the cut cycle. To use this feature, press down on the foot switch located at the front of the machine until the clamp comes down on the paper. To raise the clamp, release the foot switch. To make a cut, keep the foot switch pressed and press the cut buttons. Release the foot switch once the cut has been completed. Avoid placing hands under the clamp.

6.8 Knife Change Alarm and Lubrication Alarm

The Titan 265 XG has two built in alarms that will be displayed after a certain number of cuts. The knife alarm displays a message to remind the operator to change the knife. The lube alarm displays a message to remind the operator to have the machine lubricated. The lube alarm will also display the name and phone number of the Challenge dealer from which the machine was purchased. To reset either alarm, or to change the knife alarm value, see the “Operating Controls/Maintenance Mode/Parameters/ Knife Count” section on page 28 . The lube alarm value is factory set at 2,500 cuts and cannot be changed.

NOTE: The alarms do not prevent normal operation; they are simply reminders.

6.9 Electric Eyes

The electric eyes prevent reaching into the cutting area while a cut is being made. If the beams are broken while a cut is being made, the knife and clamp will return to the up position.

6.10 False Clamp Plate

The false clamp plate is an optional attachment, which reduces the creasing of paper caused by the clamp. The disadvantage of using the false clamp plate is that it limits the smallest cut dimension. The machine has a built-in sensor that detects when the false clamp plate is installed, and the computer will automatically restrict the backgauge position accordingly.

6.11 Display Panel

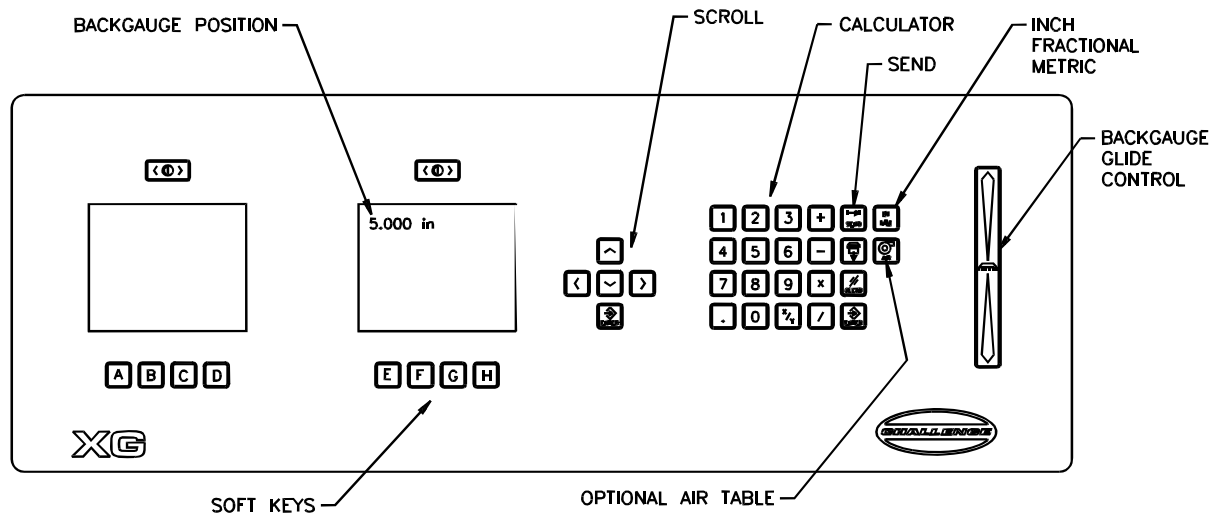

6.12 Definition of Keys

6.12.1 Backgauge Glide Control

The backgauge glide control is used to manually position the backgauge. The speed of the backgauge will depend upon where the actuator is pressed. Press farther from center for a faster speed, and closer to center for a slower speed. To move the backgauge forward, press downward. To move the backgauge backward, press upward.

6.12.2 IN/MM Key



This key toggles the display to show the position and programmed send values in inches (e.g. 5.250), inch fractions to the nearest 1/64" (e.g. 5_1/4), or millimeters (e.g. 133.3).

6.12.3 Air Table ON/OFF Key



This key turns the air table on and off.

6.12.4 Send Key



The SEND key is used to send the backgauge to any valid position. If an attempt is made to send the backgauge to an illegal position, an error message will be displayed at the bottom of the screen stating "Number outside limit". In the Job mode, the SEND key will also advance the backgauge to the next sequential cut position before performing the cut.

6.12.5 Push-Out Key



The push-out key will move the backgauge forward 5 inches (or to the most forward position) and then return it to its previous position. This allows paper to be removed from the cutter without putting hands under the knife and clamp.

! CAUTION Never place hands in the clamp and knife area. Use the push-out key or the backgauge glide control to move the paper to an area where it can be reached.

6.12.6 Clear Key



The CLEAR key is used to clear error messages and the current entry line.

6.12.7 Enter Key



The ENTER key selects items in several modes and processes data that has been entered in the other modes.

6.12.8 Priority Add (X/Y) Key



The priority/add key is used for entering fractions when they are combined with whole numbers. The symbol displayed when this key is pressed is the underline symbol “_”. An example of a number entered using the priority/add key is 1_1/2.

6.12.9 Soft Keys

There are a total of eight Soft Keys labeled “A” through “H”. The functions of these keys change depending on the operating mode. The function of each key can be found on the bottom of the display screens.

6.12.10 Arrow Keys

The four arrow keys can be used in almost all screens. The arrow keys are primarily used for moving the cursor around on the screen, or to toggle between highlighted selections. In some screens, the left arrow key acts as a backspace key.

6.12.11 Contrast Control

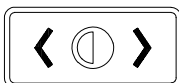

The contrast of each display screen can be adjusted by using the contrast control buttons located directly above each display screen.

6.13 Manual Backgauge Control

6.13.1 Backgauge Glide Control

The backgauge can be moved manually by use of the backgauge glide control. Press towards the operator for forward travel and away from the operator for reverse travel. The further away from center that the actuator is pushed, the faster the backgauge will travel.

6.13.2 Backgauge Control Knob

The backgauge may also be controlled using the Backgauge Control Knob located at the front of the table. Turning the knob clockwise brings the backgauge forward. Turning the knob counter-clockwise sends the backgauge backward. The further the knob is turned, the faster the backgauge will travel.

6.13.3 Backlash Indicator

To insure accurate cuts, the backgauge must be brought to the cut position from the rear of the table. In the display, to the right of the backgauge position, there is a small arrow to indicate reverse travel.

6.0 Operation

This arrow should be off when making a cut. Moving back past your cut position, then forward to it, compensates for any play in the backgauge nut and lead screw.

6.14 Send Mode

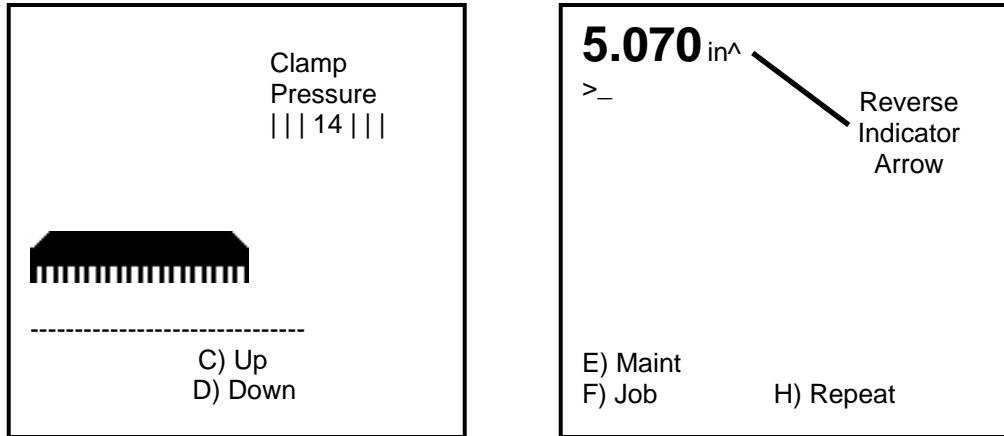

The send mode is the first screen displayed after the backgauge is preset. From this screen the backgauge can be positioned with the backgauge pinpoint control or by entering a value and pressing the SEND key. A mathematical expression can also be entered as a send value. Simply type the expression and press SEND. You can also enter an equation which begins with the current backgauge position. For example, if you want to send the backgauge 2" forward from its current position, just press [-] [2] and SEND.

The send mode screen can also be used for doing math calculations that are larger than the backgauge's reverse limit. In this case, you must press ENTER to have the result displayed on the screen.

6.14.1 Entering Math

In the simple send mode, the Titan 265 XG is capable of calculating an entire math string such as, $10-5+5 \times 6+2 \frac{3}{4}$. However, the result is limited to 29999.000 and the result cannot be a negative value. In the job mode, and during a send, the result of the calculation must be less than the backgauge limit of 30.500 inches.

6.14.2 Entering Fractions

Fractions are entered with the priority add key X/Y. The symbol displayed when this key is pressed is the underline symbol "_". This instructs the computer to add the fractional portion of the entry before performing the remaining math. This key is useful when entering a formula as follows: $3 \times 2 \frac{3}{4} = 8 \frac{1}{4}$. If a simple plus had been used instead, the result would be as follows: $3 \times 2 + \frac{3}{4} = 6 \frac{3}{4}$.

6.15 Repeat Mode

This mode allows the operator to make a series of cuts during which the backgauge moves a specified distance between each cut. To enter repeat mode, press soft-key "H" (Repeat). The display will then look like the one next:

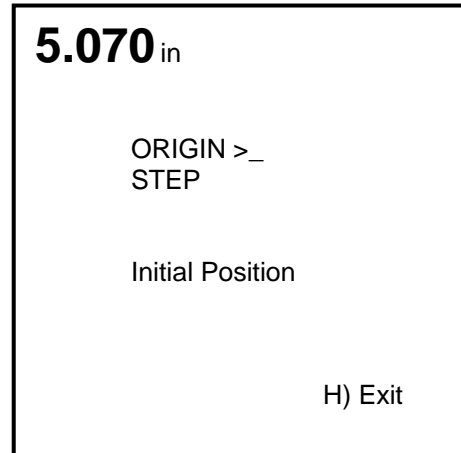
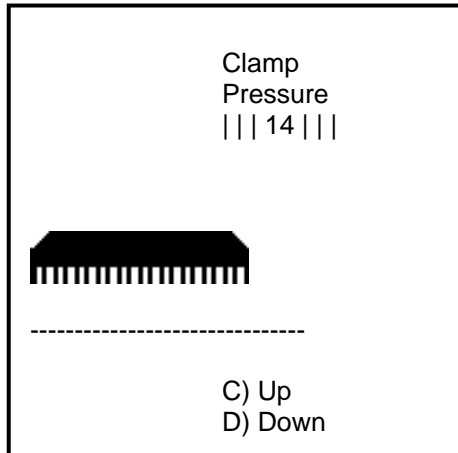

Type in the desired initial backgauge position and press ENTER. The backgauge will then move to that position. Then type in the step value and press ENTER. Position the paper and make a cut. The backgauge will then move forward by the step amount, and a new cut can be made. When finished, press soft-key "H" (Exit) to exit back to send mode.

6.16 Maintenance Mode

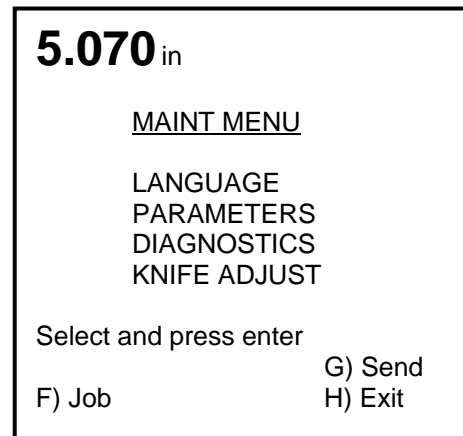
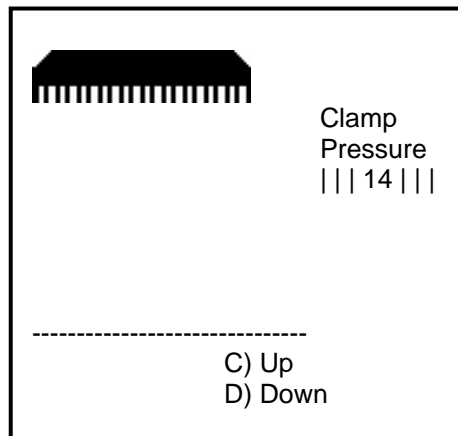

The maintenance mode is an area where many machine functions can be set or modified. The four principle functions are: Language, Parameters, Diagnostic, and Knife Adjust. To select a particular function, use the up and down arrow keys to toggle to the desired function and press ENTER. See the following descriptions for an explanation of each function.

6.16.1 Language

In the language screen, use the up and down arrow keys to toggle to the desired language, and press ENTER. All messages will be displayed in the selected language.

6.16.2 Parameters

In the parameter screen, use the up and down arrow keys to toggle to the desired parameter, and press ENTER. See the descriptions that follow for an explanation of each parameter.

6.0 Operation

6.16.2.1 False Clamp

The Titan 265 has a sensor that determines when the false clamp plate is installed. This parameter shows whether the false clamp is installed or not.

6.16.2.2 Time-out

This parameter sets the amount of idle time for which the screen saver activates and the line lights and hydraulic motor turn off. The choices are 2, 5, 10, 20, and 30 minutes. In the time-out screen, use the up and down arrow keys to toggle to the desired time-out, and press ENTER.

6.16.2.3 Push-out

Normally, whenever the backgauge is sent to a larger dimension, a five-inch (127mm) push-out is performed to aid the operator in accessing the paper. In some situations, it may be necessary to turn this feature off. It is recommended that this feature be left on whenever possible. In the push-out screen, use the up and down arrow keys to toggle to the on or off status as desired, and press ENTER.

6.16.2.4 Accuracy Adjust

This parameter provides a means for adjusting the accuracy of the backgauge. To change the accuracy, send the backgauge to 2 inches (50.8mm) and cut some paper. Measure the paper, and type in what you actually measure. The computer will calculate the amount of error and will compensate. A value may also be added to or subtracted from the current value.

6.16.2.5 Knife Count

The knife count parameter allows the operator to reset the knife alarm and the lube alarm. The knife alarm displays a message to remind the operator to change the knife. The lube alarm displays a message to remind the operator to have the machine lubricated. The lube alarm will also display the name and phone number of the Challenge dealer from which the machine was purchased.

There are three functions within the knife count parameter: Clear Count, Knife Alarm, and Clear Lube. Select the desired function and press ENTER. See the following descriptions for an explanation of each function.

Select **Clear count** to reset the knife counter when a knife change has been performed.

Select **Knife Alarm** to enter or change the knife stroke alarm value. When this value is reached, the display will alert you to change the knife and reset the knife counter. Knife alarm values for the Titan 265 XG are factory set at 2,500 cuts. However, you may want to change this value based on your specific machine applications. See the Knife section for help in choosing a knife alarm value for your machine.

Select **Clear lube** to reset the lube alarm after performing the lubrication requirements as shown in the Lubrication section of this manual. NOTE: The alarm will activate after 2,500 cuts. This value is set at the factory and cannot be changed.

6.16.2.6 Machine count

The number displayed is the total number of cuts made by the machine.

6.16.3 Diagnostic

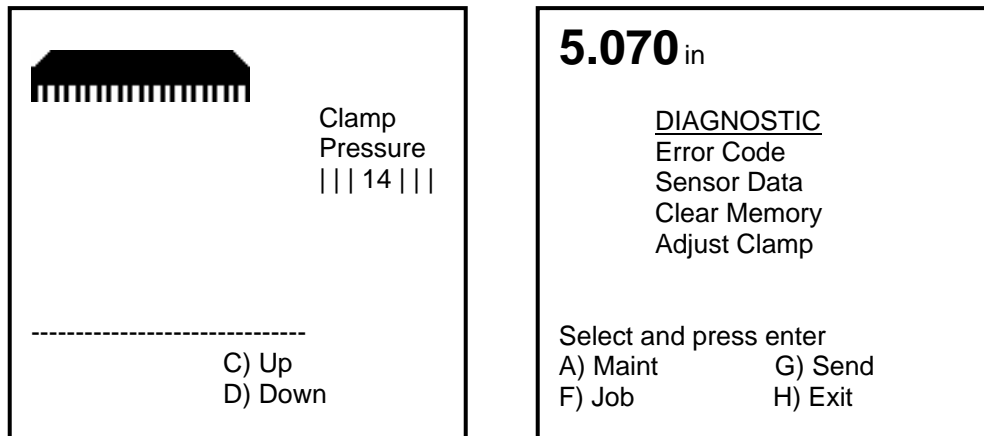

The diagnostic area can be very helpful in locating a problem in the event of a machine malfunction. Use the up and down arrow keys to toggle to the desired selection, and press ENTER. See the following descriptions for an explanation of each.

6.16.3.1 Error Code

The Error Code function simply recalls the last five error messages that were displayed. This can be very useful in cases when the malfunction cannot be reproduced in the presence of the service technician.

6.16.3.2 Sensor Data

The Sensor Data function provides a list of computer inputs and outputs (proximity switches, etc.) along with their status (0 for open, 1 for closed). This function allows a service technician to check the status of a switch without removing any covers. Cuts and backgauge movements are allowed in this screen so that the technician may observe the status of the inputs and outputs during machine operation.

6.16.3.3 Clear Memory

The Clear Memory function resets the memory to a known state. **All cut positions will be erased during this operation.**

6.16.3.4 Knife Adjust

The knife adjust function provides a way for the service technician to change the knife. In the Knife Adjust screen, use the up and down arrow keys to toggle to the up or down status as desired, and press ENTER. Press and hold the cut buttons to send the knife to the desired position.

6.17 Job Mode

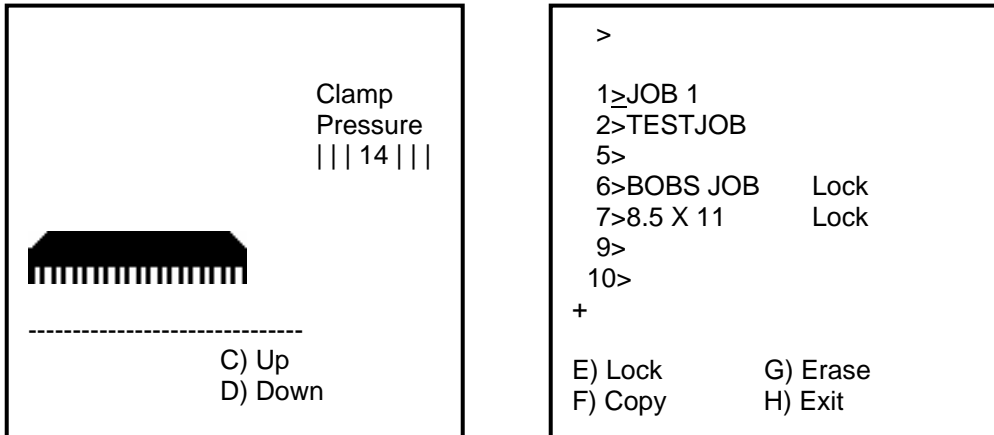

The Titan 265 XG can be programmed for up to 99 different jobs. A job is a sequence of programmed cut positions. The backgauge moves to each position after a cut cycle is made. Each job can hold up to 99 send values. Job mode is entered by pressing soft-key “F”. When the job mode is entered, all previously programmed jobs will be displayed along with their name and lock status. Locked jobs display the word “Lock” after their name. A plus “+” sign at the bottom of the screen indicates there are more jobs programmed than what are displayed. Pressing the left arrow key and the down arrow key simultaneously will page down to the next set of jobs. Page 59 contains an example of how to program a job.

6.17.1 Lock/Unlocking a Job

In the Job Mode screen, the soft-key “E” will display “Lock” or “Unlock” depending on the current status of the job. If a job is locked, the word “Lock” will be displayed to the right of the job name. Locking a job prevents it from being edited. To change the lock status of a job, simply move the cursor to the desired job using the up and down arrow keys, and press the soft-key “E” (Lock/Unlock).

6.17.2 Copying a Job

First, select a job to copy by moving the cursor up or down to the desired job number and press the soft-key “F” (Copy). “Select Copy to #” will be displayed at the bottom of the screen. Enter a job number for the new job or move the cursor to an existing job and press ENTER. If the new job is locked, the copy will not be allowed. NOTE: if the new job is not locked, but contains data, the old data WILL BE LOST.

6.17.3 Erasing a Job

Select a job to erase by moving the cursor to the desired job. Press the soft-key “G” (Erase). “Clear channel #” will be displayed, followed by YES or NO. Use the up and down arrow keys to toggle to YES or NO. YES will erase the job, NO will leave the job unchanged. NOTE: locked jobs cannot be erased.

6.17.4 Creating a New Job

To create a new job, type in a number that is not already assigned to a job and press ENTER (entering a job number greater than 99 will create job #99). The cursor will move to the line

corresponding to the number you typed in, prompting you for a job name. If no job name is desired, simply press ENTER again to begin entering send values (see below). To name the job, press the right arrow key to move the cursor to the first character position. Enter a character of the alphabet by using the up and down arrow keys to toggle to the desired character. The numeric keys can be used to enter numbers directly into the job name. When the desired character is in place, use the right arrow key to move to the next character position. The job name can be up to 10 characters long. A letter can be removed from the job name by moving the cursor to the undesired character and pressing the CLEAR key. When finished, press ENTER to save the name and to begin entering send values. The screen should now look similar to the one below:

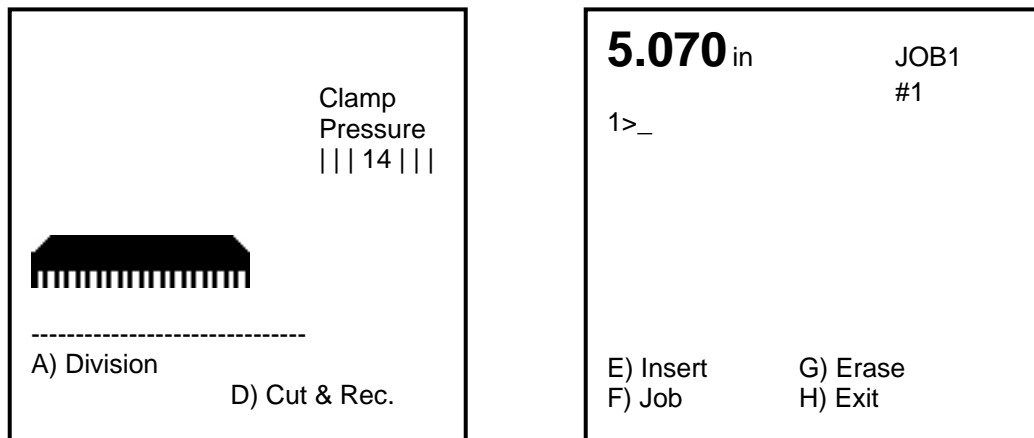

6.17.4.1 Entering Send Value

Send values can now be entered by using any of the following methods: 1) Type in the desired value and press ENTER, 2) Press ENTER at a blank line - this will enter the current position of the backgauge as a send value, 3) Use the "Cut and Record" feature (described later) or 4) Use the "Sheet Division" feature.

6.17.4.2 Creating a Stock Loading Position

After typing a send value, pressing the right arrow key instead of ENTER will move the cursor to the right and prompt the operator to enter a rotation indicator mark or Load Zone (LZ). Selecting LZ will make it impossible to cut at that position. Pressing both cut buttons on a position marked at a Loading Zone will prompt the backgauge to move to the next position in the job. Using a loading position eliminates the need to reach into the knife/clamp area of the cutter when loading a job.

6.17.4.3 Entering Rotation Mark

After typing in a send value, pressing the right arrow key instead of ENTER will move the cursor to the right and prompt the operator to enter a rotation indicator mark. The display will look similar to the one shown next:

6.0 Operation

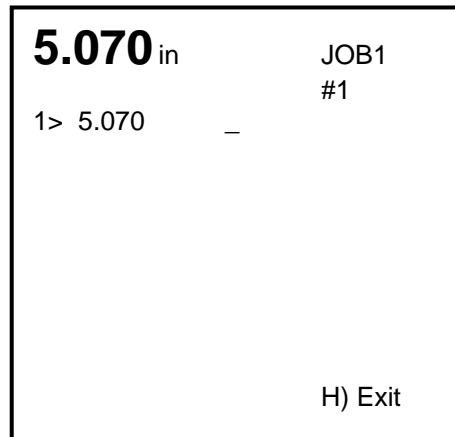
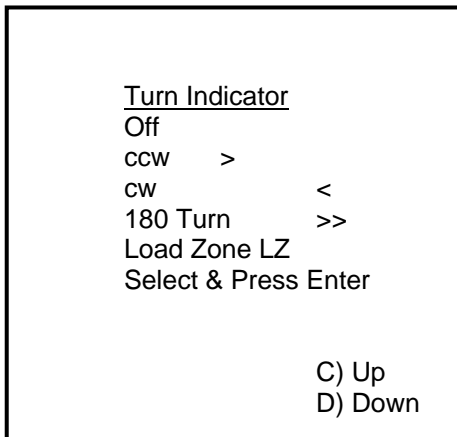

Use Soft Keys “C” and “D” to choose a turn indicator. Pressing ENTER will place an indicator mark to the right of the send value, as shown below:

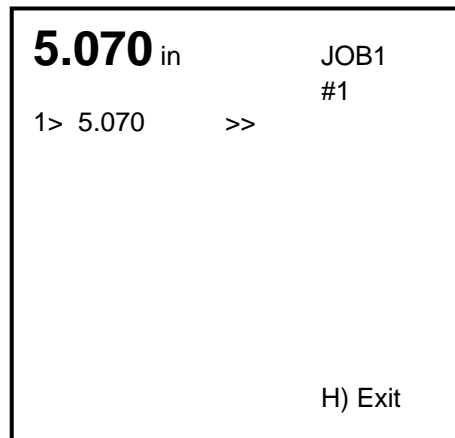
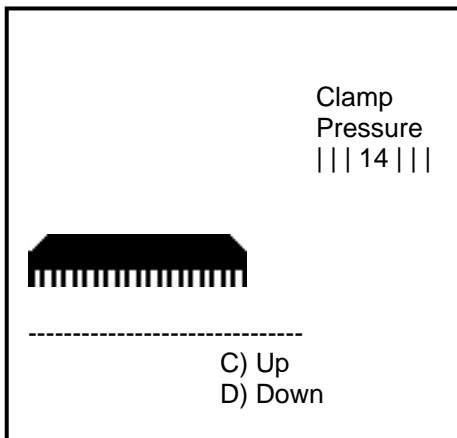

When the desired indicator mark is in place, press the right arrow key. The cursor will move to the right and prompt the operator to enter a clamp pressure (see the following section).

NOTE: All new entry lines will have the same turn indicator mark as the one above it, until it is changed.

6.17.4.4 Entering the Clamp Pressure

A separate clamp pressure can be entered for each cut in a job. To enter the desired clamp pressure, first enter the desired send value (described above), then press the right arrow key and enter the rotation mark if necessary (described above), then press the right arrow key again to move the cursor to where the clamp pressure can be entered. Use Soft Keys “C” and “D” to increase or decrease the clamp pressure, or use the numeric keypad to enter a number from 0 to 15 (see Adjusting the Clamp Pressure section, page 22 for information about the clamp pressure setting). This will complete the entry for the current line and move the cursor to the send value of the next line.

NOTE: All new entry lines will have the same clamp pressure as the one above it, until it is changed.

6.17.4.5 Cut and Record

To use this feature when creating a new job, simply send the backgauge to a desired position using the backgauge glide control or by using SEND, then make a cut. The current backgauge position will automatically be displayed in the next available cut location and the operator will be prompted to

press ENTER to record the current value. If ENTER is not pressed, the value will not be recorded into the job as a send value. This can be very convenient for setting up a program when the actual cut positions are not known.

6.17.4.6 Sheet Division Feature

The Titan 265 XG has a sheet division feature that automatically creates a complete set of send values using the parent and finished sheet sizes specified by the user. Since this feature creates an entire set of send values, it is best to use it only when creating a new job. However, this feature can also be used when editing or using an existing job. It will simply insert the new set of send values after the current send value.

Begin by pressing soft-key "A" (Division). The display will be similar to the following:

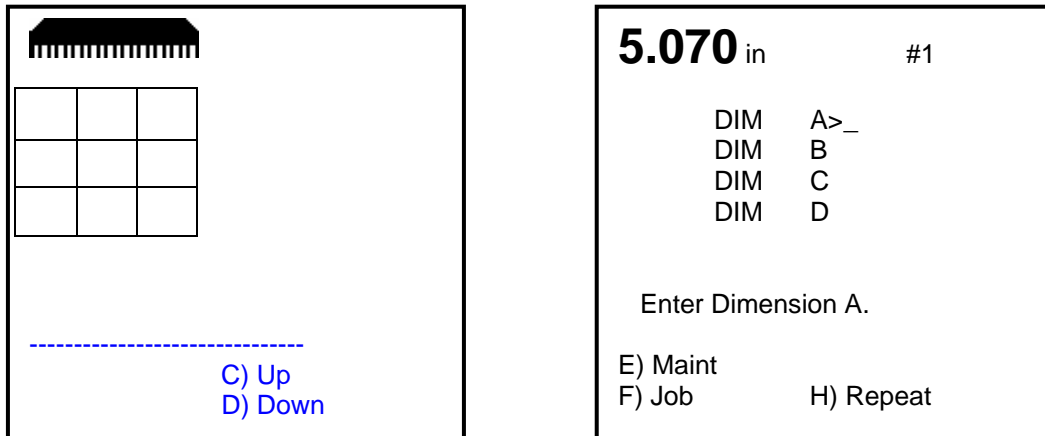

The program guides the operator through the steps of entering the necessary dimensions. Then the program asks if the columns are to be cut separate (as opposed to stacking the columns and cutting them all at once). Press "1" for Yes and "0" for No. The display will now look similar to the one shown on the next page (it may vary based on the input).

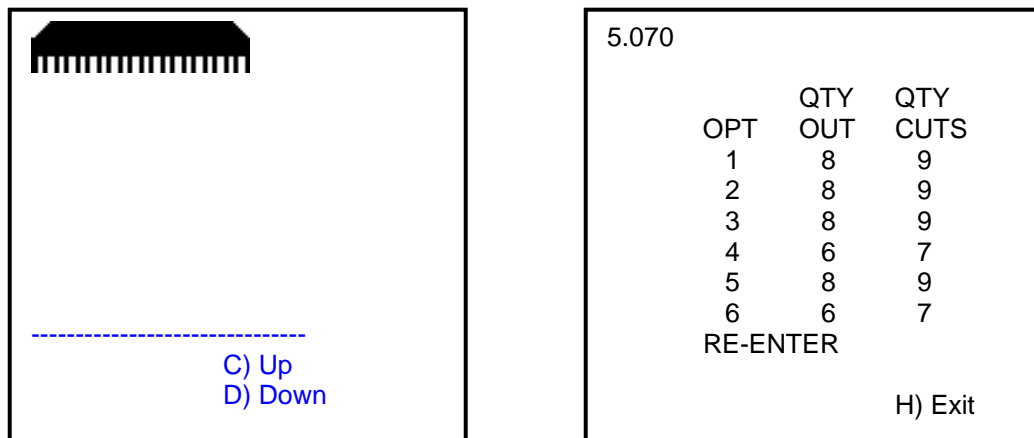

Use the up and down arrow keys to scroll through the possible layouts. The left display will show each choice visually. Select the desired option and press ENTER. The send values will be automatically calculated and entered. The job will be complete and ready for use. To make changes, edit the job as described in the "Editing a Job" section below.

6.0 Operation

6.17.4.7 Label Cutting

A label cutting feature is also provided on the Titan 265 XG. After providing the label quantity, size, and gutter, the machine will automatically create a programmed job. Begin by entering the job mode, select a job number and name (optional) then depress ENTER. Depress the soft-key "C" (Label) under the left hand display. The display will be similar to the following:

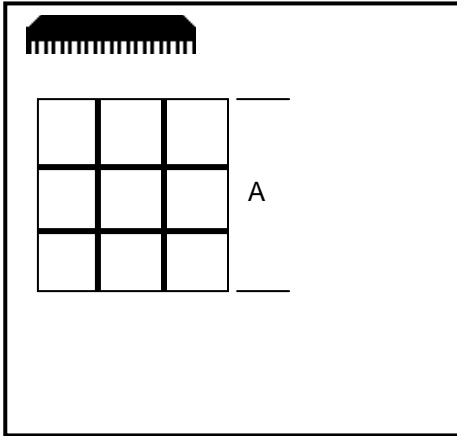

```
5.070 in          #1
*Label Cutting*

QTY  A>_
QTY  B
DIM  C
DIM  D
DIM  E
DIM  F
      Enter Quantity A.
E) Maint
F) Job          H) Repeat
```

The program guides the operator through the steps of entering the necessary information. A & B are label quantities, C & D are the actual label size and E & F are gutter dimensions. Then the program asks if the columns are to be cut separate (as opposed to stacking the columns and cutting them all at once). Press "1" for Yes and "0" for No. The display will now look similar to the one shown on the next page (it will vary based on the input).

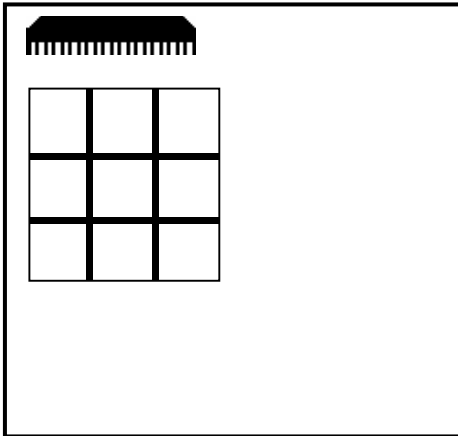

```
5.070

      QTY  QTY
      OPT  OUT CUTS
      1    8    9

      RE-ENTER (0)
      Select and Press Enter

      H) Exit
```

Use the up and down arrow keys to scroll through the possible options (if more than one). The left display will show each choice visually. Select the desired option, then press ENTER. At this point the send values will be automatically calculated and entered. The job will be complete and ready for use. To make changes, edit the job as described in the "Editing a Job" section below.

6.17.4.8 When Finished

When finished entering send values you may exit the current job by pressing soft-key "B" (Job) to go back to the job mode screen or soft-key "D" (Exit) to exit to send mode. Or you may use the current job for cutting by pressing the down arrow at the last line and following the instructions in the "Running a Job" section (page 36).

6.17.5 Editing an Existing Job

6.17.5.1 Editing the Job Name

The job name can be edited (or added if an existing job does not have a name) in the job mode screen. To edit the name, move the cursor down to the desired job number by pressing the down arrow key. Then press the right arrow key to move the cursor to the desired character position and edit the character by pressing the up or down arrow keys to toggle between characters of the alphabet. Numbers can be entered directly by using the number keys. Pressing CLEAR clears the current character. When finished, you may either go to the current job by pressing ENTER, or go to a different job, or exit job mode.

6.17.5.2 Editing Send Values

To edit send values of an existing job, start by opening the desired job from the job mode screen. A job is opened by one of two methods: pointing at the desired job with the cursor and pressing ENTER, or by entering the job number with the keypad and pressing ENTER. Once a job has been opened, the current job number will be displayed in the upper right corner. NOTE: If the job is locked, it cannot be edited.

Send values can now be edited by moving the cursor up or down to the desired send value and then typing over the existing value. To page up and page down, press the left and down arrow keys simultaneously.

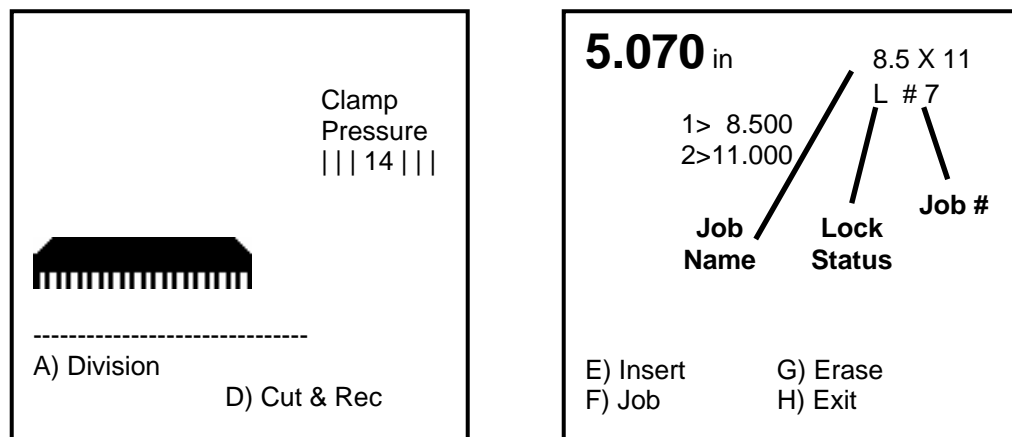

To insert a send value, press the soft-key "E" (Insert). This moves all send values down and provides a blank line after the current send value.

Send values can also be entered using the "Cut and Record" feature. Move the cursor to the line where the send values are to be inserted. Then press soft-key "D" (Cut & Rec). "C & R" will appear in the upper right corner of the left display. Each cut will add the current backgauge position as a send value. When finished, press soft-key "D" (Cut & Rec) again to exit cut & record mode. If there is a blank line where the cursor is, press the down arrow and it will disappear.

To erase a send value, press the soft-key "G" (Erase). This will remove the cut value currently being pointed to by the cursor. To backspace over the current send value without removing the line, press the left arrow key.

When finished editing the job, you may exit the current job by pressing soft-key "F" (Job) to go back to the job mode screen or soft-key "H" (Exit) to exit to send mode. Or you may use the job for cutting since it is already open.

6.17.6 Running a Programmed Job

To use an existing job for cutting, you must first open it by using one of two methods: move the cursor to the desired job with the arrow keys and press ENTER, or enter the job number with the keypad and press ENTER. Once a job has been opened, the current job name and number will be displayed in the upper right corner. Now press SEND to move the backgauge to the first programmed position (or send value). Make a cut by pressing both cut buttons. Once the cut is made, the backgauge will automatically push out the paper (only if the next position is larger than the current one, and if "push-out" is enabled) and move to the next programmed position. If the job was created using the "Sheet Division" feature, the left screen will display a diagram of where to place the paper for each cut. After the last cut in the job is made, the backgauge will move to the first cut position of the current job. Pressing SEND at any time during the job will send the backgauge to its next programmed position without making a cut. A plus "+" sign will be displayed at the bottom of the screen if more cuts remain in the current job.

6.17.7 Exiting a Job

To exit an open job, press the soft-key "F" (Job) to return to the job mode screen, or press the soft-key "H" (Exit) to exit to the send mode screen.

6.18 An Example Job

The following is an example of how to program a job that will be used to make two cuts: one at 8.5" and one at 11".

1. Turn on the machine and press CLEAR to preset the backgauge. Press the soft-key "F" (Job) to go to job mode.
2. Type in an unused job number and press ENTER. Note: It must be a number that does not correspond to an existing job. All existing jobs will be displayed on the screen (you may have to scroll through them to see them all). If you wish to replace an existing job with the new job, first erase the existing job by moving the cursor to it and press the soft-key "G" (Erase). Now type in the new number and press ENTER. In this example, job #'s 1, 2, 5, and 6 already exist. We will use job # 7 for our new job. Press "7" and ENTER.
3. The cursor will move down to the new job number. At this point, press the right arrow key once to move the cursor to the first character position. Now name the job "8.5 X 11". To do this, press "8" on the number keypad. Then press the decimal "." key and so on. To enter the spaces and the letter "X", use the up and down arrow keys to toggle through the alphabet and press the right arrow key to move to the next character position.

Now press ENTER to begin programming the job.

4. To enter the first send value of 8.5", simply type in 8.5 and press ENTER. The cursor will move to the second line. Now type 11 and press enter. At this point, you could exit and save the job by pressing the soft-key "H" (Exit) to exit to send mode, or the soft-key "F" (Job) to exit back to the job mode screen. However, lets use this job to cut paper.
5. Press the down arrow key once. This will remove the blank line 3 and move the cursor to the first send value (8.5"). Now press SEND. The backgauge will move to the 8.5" position. Place the paper to be cut against the backgauge and press the cut buttons. Once the cut cycle is complete, the backgauge will push out the paper and move to the next send value (11"). Now position the paper again and make another cut. After the cut is made, the backgauge will push out the stock and return to the first cut position, ready to repeat the current job.

6. Now lets lock the current job so it cannot be edited. First, exit back to job mode by pressing soft-key "F" (Job). Now move the cursor down to the new job using the down arrow key. Now press the soft-key "E" (Lock) to lock the job. A lock symbol will appear indicating the job has been locked.
7. To exit back to send mode, press the soft-key "H" (Exit).

6.19 Operating Tips

Carefully lay out each sheet before you start cutting. Find the best cut pattern to give you the most pieces out of the sheet. If the sheet will be folded, be sure grain of the paper is running in the same direction as the fold or you will get a rough edge on the fold.

If an accurate cut is necessary for close register work, you **MUST** have a sharp blade in the cutter. A dull blade will pull or draw the paper and cause uneven cutting. Increased clamp pressure will not eliminate draw caused by a dull knife.

The correct clamping pressure varies from paper to paper. The general rule is that you should have enough pressure to hold the paper securely but not so much that it marks the surface of the paper excessively. Excessive pressure causes pile distortion and inaccurate cuts.

Mark the gripper edge and the guide edge of printed paper and make sure the first cuts are with these guide edges against the backgauge.

Measure printed paper to check for shrinkage or expansion of the paper from humidity. You may have to disregard the printed cut lines and make your own.

When cutting business cards or narrow strips of paper, place lifts of equal height on opposite sides of the table to prevent wear of the clamp guides.

7.0 Knife Installation/Changing

⚠ CAUTION

Changing knives can be very dangerous unless safety precautions are observed and extreme care is taken when handling knives.

- Make sure knife lifters are properly installed, see instructions following.
- Keep handling of unprotected knives to an absolute minimum.
- Clear off cutter table before removing knife.
- Have scabbard on cutter table and insert knife immediately.
- Warn people of any unprotected knife.
- Knife changing is a **ONE PERSON OPERATION**. Having more than one person trying to change knives invites accidents.

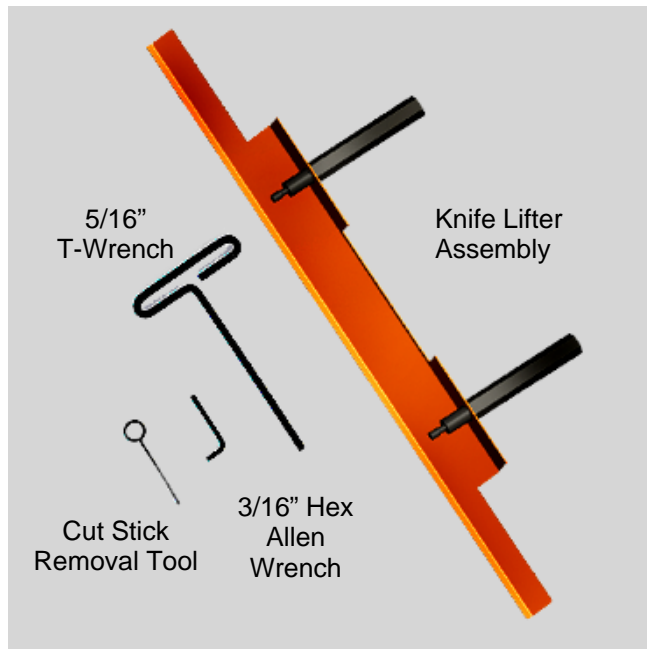

Figure 19 – Knife Changing Equipment

The knife changing equipment shown in Figure 19 is included in the cutter tool kit. The following instructions show how to remove and install a new or re-sharpened knife. Read through these instructions **AT LEAST ONCE** before attempting to actually change or install any blades.

7.1 Knife Removal

1. Make sure the knife and clamp are in the “up” position. Turn the power off and lockout power to machine, see Power Lockout Procedure, page 5.
2. Back off the knife adjusting screws on top of the knife bar several turns (Figure 20). A new knife will cut deeper than one that has been ground several times. Failure to back off the screws could damage the knife and/or the cutting stick.

Knife Adjusting Screws

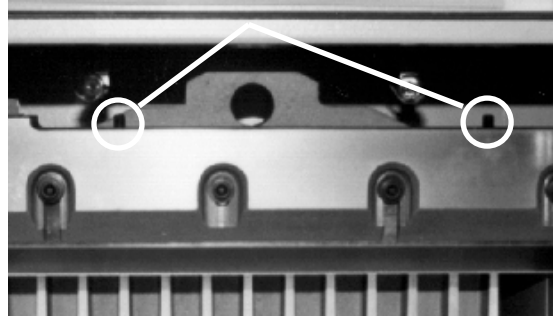

Figure 20

3. Remove the knife bolts from the two slotted knife bar holes and replace with the knife lifters (Figure 21). Tighten the lifters to hold the knife in place, and then remove the remaining knife bolts.



Figure 21

4. Clear the table surfaces and place the empty knife scabbard on the table. Remove the scabbard's knife retaining screws.
5. Grasp the knife lifters firmly and, at the same time, turn them counterclockwise to release the knife from the knife bar (Figure 22). Lower the left end first, then lower the right end as you shift the knife sideways to the left. Bring the right end of the knife out from the machine. Shift the knife to the right and bring out the left end. Put the blade in the scabbard immediately and secure the knife retainer screws.



Figure 22

7.2 Knife Installation

CAUTION

Knives are heavy and always very sharp! Be sure to keep the edge away from your body and keep other people out of the area while handling the blade. Severe lacerations or dismemberment could result from careless handling procedures.

1. Make sure the knife and clamp are in the up position. If they are not, turn on the power and press the CLEAR button. Once the backgauge is preset, press both cut buttons to send the knife and clamp up.
2. Turn the power off and lockout power to machine, see Power Lockout Procedure, page 5.
3. Pull out the cutting stick using the cut stick removal tool and turn it to a new surface. If the cutting stick is not level or flush with the table, 1/2" strips of paper can be placed in the table slot under the cutting stick to shim it.
4. Remove the left retainer screw from the new blade and screw the knife lifter assembly into the new blade. Screw the lifters all the way in and then back them out a 3/4 turn).
5. Remove the other scabbard retainer screw.
6. Double check to make sure the knife adjusting screws have been backed out all the way (Figure 20, page 39). Guide the blade, left edge first, into the space between the knife bar guide frames on the left. Move the right end of the blade into the machine, under the knife bar slot. Align the lifters with the slots in the knife bar, raise the knife into the knife bar slot as high as it will go and tighten the lifters.

NOTE: If the blade will not go in, either the lifters are screwed into the blade too far, or the end of the blade is hitting the cylinder bracket at the right end of the knife slot. In this case, drop the left end when inserting the knife.

7. Insert the knife bolts with washers and snug to hold the knife, but don't tighten them yet.
8. Remove the knife lifter assembly and replace with bolts and washers.
9. Place a few sheets of paper over the cut stick, covering the stick end-to-end.
10. Restore power to machine and turn power on.
11. Go to the MAINTENANCE screen and choose KNIFE ADJUST. Choose KNIFE DOWN, then press and hold the cut buttons to send the knife to the down position.
12. Turn the power off and lockout power to machine.
13. Turn the knife adjusters down evenly, a little at a time, until the knife cuts through the bottom sheet of paper the entire length of the cutting stick (Figure 23). Turning the screws down evenly prevents uneven wear on the knife and cutting stick.

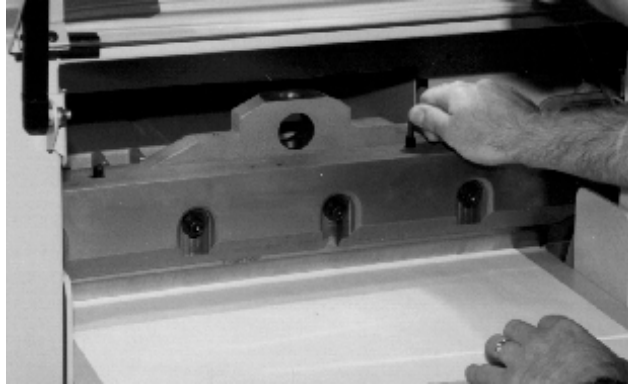

Figure 23

14. Restore power to machine and turn power on.
15. Press CLEAR. This will raise the knife and clamp to the up position.
16. Turn the power off and lockout power to machine.
17. Tighten all knife bolts securely.
18. Restore power to machine and turn power on. Make a test cut through a full lift of paper and make minor adjustments if necessary by repeating steps 9 through 17. **NOTE:** If the knife ends cut but the middle doesn't, you could have dips or uneven spots in the knife and/or cutting stick. These can be eliminated by placing 1/2" strips of paper in the table slot beneath the cutting stick to shim it.
19. Send the dull knife to a knife grinder. Do not attempt to sharpen your own knives! See the Knife Care Tips Section below to determine the knife bevel angle.

7.3 Knife Care Tips

⚠ CAUTION ! **KNIFE SAFETY** ! Knives are **DANGEROUS!!!** They are heavy and very sharp, even after use. Keep the edge away from your body and keep the area clear of others when handling knives. Never touch the cutting edge! To prevent personal injury and damage to the knife, always keep knives in their holders with screws tightened. You are aware of the dangers, but others may not be. Never attempt to hone, polish, or service the knife in any way. Failure to follow safety procedures may result in severe lacerations or dismemberment.

7.3.1 Knife Blade Life

Knife blade life, or the time between sharpenings, can be affected by many factors. One important factor is the type of paper being cut. Abrasive paper, such as recycled paper, soft paper such as newsprint paper, and bound books can all significantly shorten knife blade life. Also, if the knife depth is set too deep, the knife will cut too deep into the cutting stick and can dull the knife blade.

A knife can last between 2,000 and 5,000 cuts before it needs to be sharpened. Cutting soft paper (such as newsprint paper) or paper with high post-consumer recycled content can cause the knife to need sharpening after only 2,000 to 3,000 cuts. Cutting pure paper, such as bond paper with no recycled content, or hard paper can allow the knife to be used for as many as 5,000 cuts before it needs to be sharpened. In all cases, the operator should continually check the quality of the cut to determine when the knife blade needs to be sharpened. Some characteristics that indicate a blade needs sharpening are:

7.0 Knife Installation/Changing

- The knife hesitates or stalls while making a cut.
- The sheets are not all cut to the same length (usually the top few sheets are longer than the rest of the sheets - this is sometimes called “draw”).
- Cut marks appear on the cut face of the paper.
- The profile of the cut (side view) is not perpendicular to the table.
- The cut does not appear straight when viewed from the top.
- The knife makes a “rougher” sound as it passes through paper.
- Nicks are visible on the cutting edge of the knife.

7.3.2 Cutting Stick

A worn cutting stick can affect the cut quality of the bottom sheets. When this happens, the cut stick can be rotated. Usually, the stick should be rotated one or two times between knife sharpenings.

There are 8 possible cut stick positions. The stick can be rotated 4 times, and then turned end to end, and rotated 4 times again.

7.3.3 Bevel Angle

Challenge recommends that bevel angles for the Titan 265 knives be in the range of 21° to 23°. In general, a 21° bevel angle will provide better cut quality when cutting soft paper (such as newsprint), recycled paper, or bound books. However, 21° angle knives can become dull sooner than 23° knives, which results in shorter knife blade life. A knife with a 23° bevel angle, on the other hand, will not dull as easily, and can provide satisfactory results when cutting most types of paper. Knives shipped with the Titan 265 from the factory have a bevel angle of 23°.

7.3.4 Helpful Suggestions

- If your establishment is large enough to purchase more than one set of knives, have one set beveled at 21° and the other at 23°. Note: A set consists of 3 knives: one in the machine, one as a back up, and one at the grinder.
- If the machine seems to strain but the cut quality is still good, reduce the pile height. You may also carefully apply glycerin to the bevel when cutting hard, coated paper. Tie a cloth to the end of a stick; dip the stick in glycerin, and apply. Never apply by hand! In lieu of glycerin you may lightly rub white bar soap along the bevel. Lubrication will prolong the life of your machine and reduce maintenance.

7.3.5 Knife Care

- To prevent corrosion, knives are coated with light oil. It should be REMOVED WITH CARE.
- While removing or installing a knife, be careful not to allow the edge to bump against the machine. Nicks will result.
- If a knife bolt is damaged, replace it.

- Always keep knife bolts securely tightened.
- Always use the heavy-duty knife bolt washers provided by Challenge. Failure to do so could result in scratching or marring of the clamp face.
- Store knives in a dry environment to prevent corrosion.
- Never attempt to service a knife in any way.

8.0 Safety Systems Test

Machine manufacturer CHALLENGE

Model TITAN 265

Serial Number _____

Frequency of test: **THESE TESTS SHOULD BE PERFORMED AT THE BEGINNING OF EACH WORK DAY.**

Turn the power on and press CLEAR to preset the backgauge. Make sure the knife and clamp are in the up position (if they are not, follow the instructions in this manual to send them up).

Test #1: Wave a test object 12mm in diameter between the electric eye beams. The indicator lights should indicate the eyes are blocked. If they do not, do not use the machine. Repair or adjustment is needed.

Test #2: While making a cut, lean into the electric eye beams. The knife and clamp should immediately return to the up position. If they do not, do not use the machine. Repair or adjustment is needed.

